

## Parts List

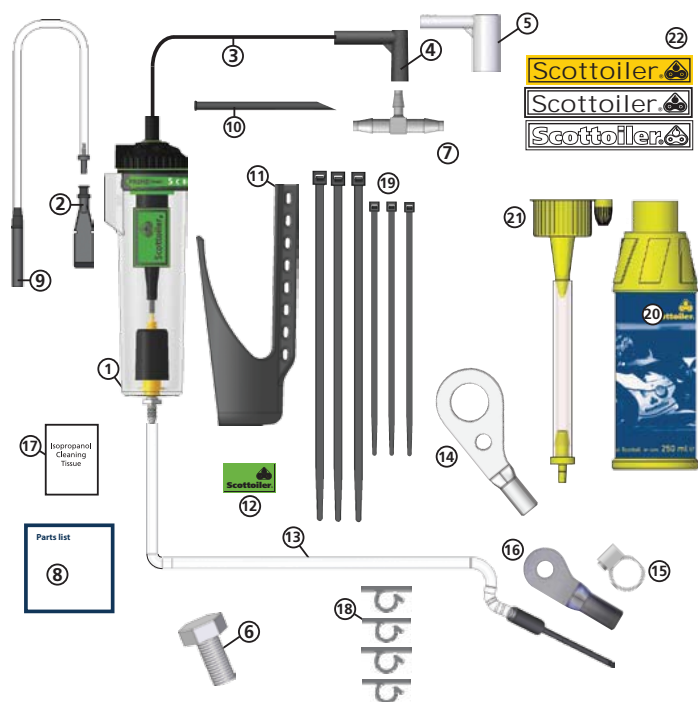

- |   |   |
|---|---|
| 1. RMV (Reservoir Metering Valve) (SO-0022) | 12. Sticker (place on chainguard) (RM-050121) |
| 2. Filler Plug (SA-0040)                    | 13. Dispenser Assembly (SA-0024)              |
| 3. Vacuum Tubing (Black) (SC-0051)          | 14. Dispenser Plate (RM-150060)               |
| 4. Vacuum Damper (SA-0100)                  | 15. Dispenser Plate Clip (RM-150065)          |
| 5. Grey Vacuum Damper (SA-0104)             | 16. Small Dispenser Plate 10mm (RM-150063)    |
| 6. M10 Fine Pitch Screw (RM-150146)         | 17. IPA Wipe (RM-100125)                      |
| 7. T-Piece (RM-150005)                      | 18. Adhesive Clips (x4) (SA-0175)             |
| 8. Instructions (SA-0084)                   | 19. Cable Ties (x6) (SA-0015)                 |
| 9. Breather Assembly (SA-0010)              | 20. 250ml Scottoil (SA-0008)                  |
| 10. Spare Nib (x2) (SA-0075)                | 21. Filling / Priming Spout (SA-0126)         |
| 11. RMV Cage (SA-0600)                      | 22. Scottoil Stickers (assorted.)             |



# vSystem

## Quick Setup Guide



Scottoil (Scotland) Limited, 2 Riverside, Milngavie, Glasgow G62 6PL

### Your Bike

Check our website, [www.scottoiler.com](http://www.scottoiler.com), for model specific installation guides showing where and how to fit on your own bike.

Vacuum Location

RMV Position

Dispenser Routing



### Additional Parts

Some models require free of charge adapter kits in order to correctly install this kit.

Where required, the additional parts will be listed on the model specific installation guide relevant to your bike, as shown above.

Found at [www.scottoiler.com](http://www.scottoiler.com).



6mm T-Piece

Chain Guard Mount Adapter

Dispenser for mounting on outside of swingarm.

## Limited Warranty

All Scottoil products are guaranteed to be free from defects in materials and workmanship for a period of two years from date of purchase.

Please register your product online at [www.scottoiler.com/guarantee](http://www.scottoiler.com/guarantee) to verify the date of purchase.

**Important:** Do not tamper with, modify or dismantle any part of your Scottoil system. Such actions could damage the product, and/or your motorcycle, and may invalidate the product warranty.

## How It Works

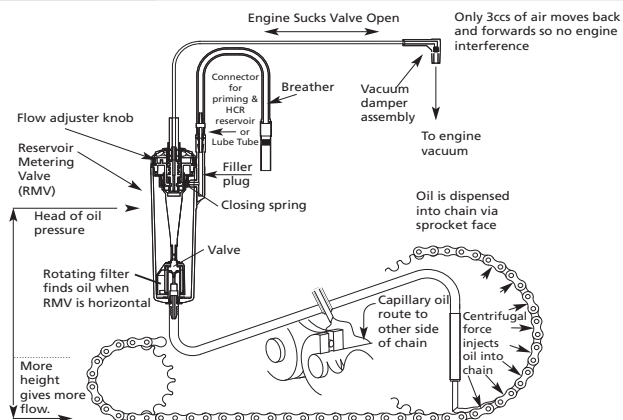

**How does the Scottoil work?** The Scottoil vSystem is vacuum operated. When the motorcycle engine is running vacuum is generated, this lifts a diaphragm which in turn opens the valve. Whilst open the valve allows oil to drip feed under gravity down the delivery tube to the chain via the rear sprocket. There is metering built into the valve to provide adjustment to control the rate at which oil is dispensed. It is not a pump.

**How does this affect the engine?** It doesn't. The Scottoil's output is not affected by engine speed, throttle opening and so on. The vacuum chamber is a sealed unit and does not affect the running of the bike. Upon starting the engine the valve will open, this requires 3cc of air to be moved in order to lift the diaphragm, which stays up until the engine is switched off. It is not unusual to see the diaphragm pulsating with very low revs, particularly on singles and twins, don't confuse this for a pumping action, it is not a pump.

## Frequently Asked Questions (FAQs)

**1. Which products are suitable for my bike?** Visit our website at [www.scottoiler.com](http://www.scottoiler.com) and select your bike 'Manufacturer' and 'Model'. Select the kit you want and download the installation guide PDF.

**2. What oil should I use to refill my Scottoil?** In ambient temperatures between 0 and 30 degrees Celcius we recommend Scottoil Traditional - Blue and in ambient temperature between 20 and 40 degrees Celcius we recommend Scottoil High Temperature - Red. Scottoil features a very low tack additive thus not attracting dirt. Scottoil cannot guarantee the compatibility of our systems using any other manufacturers' oils as the materials used are tested for compatibility and flow rates with Scottoil only.

**3. When should I refill my RMV (Reservoir Metering Valve)?** If you refill the oiler before it runs dry you won't have to prime the dispenser tube. The Reservoir Metering Valve takes around ten seconds to top up with 50ml of oil which should last approximately up to 1500 miles.

**4. Can I increase the capacity?** Yes, the Magnum High Capacity Reservoir (HCR) increases capacity by up to eight times. The HCR is fitted behind the number plate and the combined increased capacity will give up to 10,000 miles between refills. Alternatively, the Lube Tube flexible high capacity reservoir increases combined capacity by up to four times. The Lube Tube can be fitted into any dead space on the bike and will mean up to 6,000 miles between refills.

**5. Will the Scottoil only oil one side of my chain?** No. The oil is fed to the chain via the sprocket face where it splits over the inner side plates. Some of the oil is diverted onto the o-rings and the remainder feeds under the roller onto the bushing. Capillary action will then draw the oil across the chain. For best results load the chain with oil from the bottle or a rag after cleaning and then apply approx 1 drop per minute to maintain this film of oil.

**6. Will I get oil on my tyre?** No, A flow rate of approximately one drop per minute applied via the sprocket face will provide an oil-film which will not pollute the running surface of the tyre and will give a dramatic improvement in chain life. In conditions where high levels of dust, sand or heavy rain are present more oil flow will be necessary to extend chain life.

**7. Do Scottoil offer a fitting service?** No. If you have a new bike and are local to Glasgow give us a call, we might be looking for your bike. If you aren't confident about fitting the system, having looked at the model specific installation guide for your bike, we have a network of approved and trusted Scottoil dealers who will be able to fit this for you. Go to [www.scottoiler.com](http://www.scottoiler.com) and select Dealer Locator to find one closest to you.

**8. I want to move my Scottoil onto my new bike, are the spare parts available separately?** Yes, the full range of spare parts, fittings and accessories are available online at [www.scottoiler.com](http://www.scottoiler.com) or by telephoning Sales on +44 (0)141 955 1100. Alternatively, contact your local Scottoil dealer, who can order the parts on your behalf.



# Kawasaki VSystem



Visit our pages on Facebook, YouTube, Twitter and flickr.



Version 3.1

## 1. Vacuum Connection - 3 options

**Hint:** Model specific installation guides can be found at [www.scottolier.com](http://www.scottolier.com)

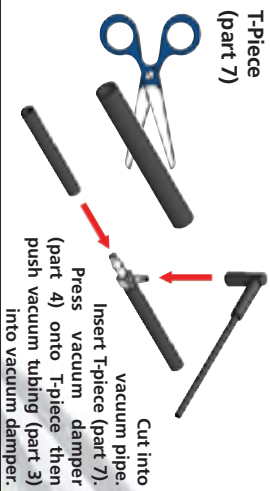

Vacuum tubing & damper elbow (part 3 & 4)

**Hint:** Lubricate damper elbow for easier installation.

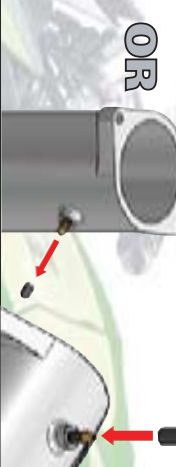

OR



Vacuum tubing & 6mm grey damper elbow (part 3 & 5)

**Hint:** Lubricate damper elbow for easier installation.

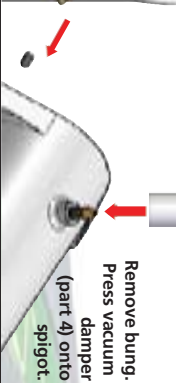

For a full parts list, system diagram & FAQs see reverse.

**Hint:** Place a Scottolier sticker on the chain guard to alert mechanics to the presence of a Scottolier system.

## 2. Dispenser Assembly - 3 most common options

**Warning:** Incorrect installation can result in excessive filing.

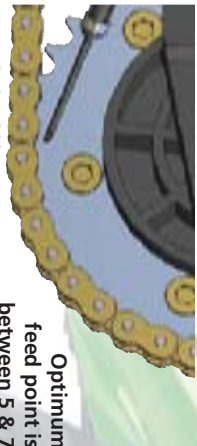

**Hint:** Nib should be lightly touching sprocket with slash cut facing out.



Bobbin mount (parts 13, 15 & 16)

Choose the mounting most suited to your motorcycle or check [www.scottolier.com](http://www.scottolier.com) for model specific install guides.



Spindle mount (parts 13 & 14/15)

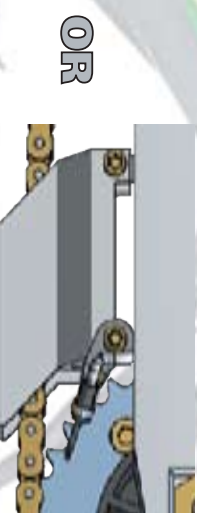

Sprocket guard (parts 13 & 15/16)

## 3. Reservoir Meeting Valve (RMV)

**Warning:** Avoid hot exhaust and engine components

Mount RMV with spigot inclined downwards and filling hole accessible.



**Hint:** The RMV should be mounted as near vertical as possible to achieve maximum capacity.



A hole can be drilled anywhere on the spine which allows mounting with an existing bolt.

## 4. Tube Routing

**Warning:** Avoid routing against moving parts

Use adhesive clips (part 18) and cable ties (part 12) to route tubing from dispenser assembly (part 13) to RMV location.

**Hint:** Use IPA wipe (part 17) to degrease surfaces before adhering.



## 5. Connections

Connect vacuum tubing and delivery tubing to the RMV.

Vacuum tubing (part 4) → Route breather up and over.

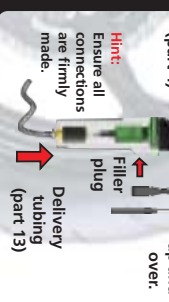

**Hint:** Ensure all connections are firmly made.

## 6. RMV Filling

Fill RMV using bottle & spout (parts 20 & 21).



**Hint:** Always remove filler plug and breather before filling.

## 7. Prime System

Press filler plug (part 2) into the RMV and set the RMV to prime.



Connect spout to the filler plug and squeeze bottle. Force oil down the delivery line until no air bubbles remain.

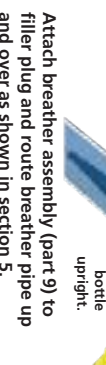

**Hint:** Hold bottle upright.

## 8. Set Flow Rate

Start your bike & allow the engine to warm up. Adjust the flow until 1 drop per minute is achieved.

Check flow after a short journey & adjust if necessary.

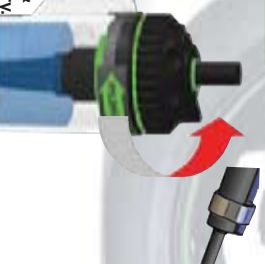

**Hint:** More than 2 drops per minute will result in excess filing.

