



# Kraftfahrt-Bundesamt

DE-24932 Flensburg

---

## ALLGEMEINE BETRIEBSERLAUBNIS (ABE)

nach § 22 in Verbindung mit § 20 Straßenverkehrs-Zulassungs-Ordnung (StVZO) in der Fassung der Bekanntmachung vom 26.04.2012 (BGBl I S.679)

Nummer der ABE: 91325\*03

Gerät: Lenkungsdämpfer

Typ: DS

Inhaber der ABE  
und Hersteller: Hyperpro Sales B.V.  
NL-4251 LR WERKENDAM

Für die oben bezeichneten reihenweise zu fertigenden oder gefertigten Geräte wird dieser Nachtrag mit folgender Maßgabe erteilt:

Die sich aus der Allgemeinen Betriebserlaubnis ergebenden Pflichten gelten sinngemäß auch für den Nachtrag.

In den bisherigen Genehmigungsunterlagen treten die aus diesem Nachtrag ersichtlichen Änderungen bzw. Ergänzungen ein.



# Kraftfahrt-Bundesamt

DE-24932 Flensburg

---

2

Nummer der ABE: 91325\*03

Die Lenkungsdämpfer, Typ DS, dürfen auch zum Anbau an die in den beiliegenden Prüfunterlagen aufgeführten Kraftfahrzeuge unter den angegebenen Bedingungen feilgeboten werden.

Im Übrigen gelten die im beiliegenden Nachtragsgutachten der GTÜ Gesellschaft für Technische Überwachung mbH, Stuttgart, vom 05.02.2015 festgehaltenen Angaben.

Flensburg, 26.02.2015

Im Auftrag

Jan Hendrik Schneider



Anlagen:

Nebenbestimmungen und Rechtsbehelfsbelehrung  
1 Nachtragsgutachten Nr. GTÜ StVZO22-14003.02



# Kraftfahrt-Bundesamt

DE-24932 Flensburg

---

Nummer der ABE: 91325\*03

- Anlage -

## Nebenbestimmungen und Rechtsbehelfsbelehrung

### Nebenbestimmungen

Die in der bisherigen Genehmigung enthaltenen Auflagen gelten auch für diesen Nachtrag.

### Rechtsbehelfsbelehrung

Gegen diese Genehmigung kann innerhalb eines Monats nach Bekanntgabe Widerspruch erhoben werden. Der Widerspruch ist beim **Kraftfahrt-Bundesamt, Fördestraße 16, 24944 Flensburg**, schriftlich oder zur Niederschrift einzulegen.

**zur Beantragung eines Nachtrags zur ABE Nr. KBA 91325\*02  
nach § 22 StVZO Austausch-Lenkungsdämpfer für Krafträder**

Fahrzeugteilart : Austausch-Lenkungsdämpfer für Krafträder  
Typ : DS  
Antragsteller : Hyper Pro Sales B.V., NL-4251 LR Werkendam

---

**1. Allgemeines**

- 1.1. Hersteller : Hyperpro Sales B.V.  
Hulsenboschstraat 26  
NL-4251 LR Werkendam  
Niederlande
- 1.2. Antragsteller : Siehe Ziff. 1.1.
- 1.3. Teileart : Austausch-Lenkungsdämpfer für Krafträder
- 1.4. Teiletyp / Handelsbezeichnung : DS
- 1.5. Varianten  
CSC : Lineare Dämpferkennlinie  
RSC : Progressive Dämpferkennlinie
- 1.6. Ausführungen : fahrzeugspezifische Abmessungen und  
Anbausätze  
Weitere Ausführungsmerkmale : siehe Anlage 1  
Codierung der Ausführungen : Beispiel: MK-DU07-T001
- 1.7. Grund des Nachtrags :  
- erweiterter Verwendungsbereich  
- redaktionelle Änderungen

- 2. Verwendungsbereich** : Verwendungsbereich und Anbauvorgaben  
siehe Anlage 1.

**3. Technische Angaben**

- 3.1. Beschreibung der Umrüstung : Lenkungsdämpfer, bestehend aus  
hydraulischem Schwingungsdämpfer und je-  
weils fahrzeugspezifischem Anbausatz.
- 3.2. Beschreibung der Bauteile : Siehe Anlage 2
- 3.3. Kennzeichnung : Herstellerlogo (Hyper Pro),  
KBA-Genehmigungsnummer,  
Code (FFFF) eingraviert
- Ort der Kennzeichnung : auf den Windungen

**zur Beantragung eines Nachtrags zur ABE Nr. KBA 91325\*02  
nach § 22 StVZO Austausch-Lenkungsdämpfer für Krafträder**

Fahrzeugteilart : Austausch-Lenkungsdämpfer für Krafträder  
Typ : DS  
Antragsteller : Hyper Pro Sales B.V., NL-4251 LR Werkendam

---

#### **4. Durchgeführte Prüfungen**

Die repräsentativen Versuchsfahrzeuge wurden einer eingehenden Begutachtung und Fahrerprobung unterzogen.

Prüfungen in Anlehnung an VdTÜV-MBL 762 " Prüfung von Zubehörfedern und Austauschfederbeinen für Kraftfahrzeuge nach §30a Abs.3 StVZO" (Stand 01/2011).

Anbauprüfungen wurden durchgeführt.

Die Betriebsfestigkeit wird durch beim Hersteller durchgeführte und dokumentierte, periodische Prüfstandsläufe für Lenkungsdämpfer und ihre Befestigungselemente geprüft.

Folgende Prüfungen wurden durchgeführt:

Stroking durability test, Überprüfung der Dämpferkennlinien über 10<sup>6</sup> Lastwechsel mit verschiedenen Hüben bei ca. 4 Hz bei mittlerer Einstellung für die Dämpferkraft und Druckstufe

Die Betriebsfestigkeit wurde außerdem durch Dauererprobung in Fahrversuchen gem. o.a. Prüfgrundlage geprüft und nachgewiesen. (Fahrstrecke: ca. 8000 km)

Bei unterschiedlichen Beladungszuständen der repräsentativen Versuchsfahrzeuge wurden bei maximaler, mittlerer und minimaler Dämpfereinstellung

- das Ansprechverhalten der Lenkungsdämpfer,
- das Lenk- und Bremsverhalten,
- das Fahrverhalten im Grenzbereich und auf schlechten Wegstrecken
- die Aussenkanten nach 97/24/EG, Kap.3

geprüft.

#### **5. Prüfergebnisse**

Eine ausreichende Betriebsfestigkeit der Teile wurde nachgewiesen.

Eine sichere Montage und ausreichende Freigängigkeit zu anderen Fahrzeugteilen ist bei sachgerechter Montage gewährleistet.

Die Teile werden nur an Originalbefestigungspunkten angebracht.

Fahr-, Lenk- und Bremsverhalten werden durch die Verwendung der Lenkungsdämpfer im Vergleich zum Serienzustand nicht negativ beeinflusst.

**zur Beantragung eines Nachtrags zur ABE Nr. KBA 91325\*02  
nach § 22 StVZO Austausch-Lenkungsdämpfer für Krafträder**

Fahrzeugteilart : Austausch-Lenkungsdämpfer für Krafträder  
Typ : DS  
Antragsteller : Hyper Pro Sales B.V., NL-4251 LR Werkendam

---

**6. Abnahme des Anbaus**

Die zur Prüfung vorgestellten Fahrzeugteile des Herstellers Hyper Pro Sales B.V. entsprechen den vorstehenden Angaben.

Die im Verwendungsbereich aufgeführten Fahrzeugtypen entsprechen nach dem Einbau der Fahrzeugteile den heute gültigen Vorschriften der StVZO sowie den hierzu vom Bundesminister für Verkehr erlassenen heute gültigen Anweisungen und Richtlinien.

Eine Prüfung des Einbaus der Fahrzeugteile und die Überprüfung der vorgeschlagenen Auflagen durch einen amtlich anerkannten Sachverständigen oder Prüfer für den Kfz-Verkehr oder einen Prüfsachverständigen einer Überwachungsorganisation wird bei eindeutiger Zuordnung des Fahrzeugs durch Nennung des Fahrzeugtyps **und** der Allgemeinen Betriebserlaubnis (ABE) bzw. EG-Typgenehmigung in Anlage 1 nicht für erforderlich gehalten.

Eine Änderung der Angaben in den Zulassungsbescheinigungen bzw. Fahrzeugpapieren wird nicht für erforderlich gehalten.

**7. Anlagen**

	<u>Stand</u>
1 Verwendungsbereich (16 Blatt)	05.02.2015
2 Beschreibung der Bauteile und beispielhafte Montageanleitungen (7 Seiten)	21.04.2014

**8. Schlussbestätigung**

Es lag beim Grundgutachten das Gutachten Nr.114KA0023-00 vom 08.03.2012 des Technischen Dienstes der TÜV Rheinland Kraftfahrt GmbH einschließlich der Genehmigung 91325 des KBA vor.

Die von der GTÜ an repräsentativen Fahrzeugen durchgeführten Prüfungen schließen auch den Verwendungsbereich des vorangegangenen Gutachtens mit ein.

Dieser Prüfbericht behandelt zusammenfassend und vollständig den Gesamtumfang der Typprüfung einschließlich der Dokumentation des Fahrzeugteils.

Stuttgart, 05.02.2015

[Technischerdienst@gtue.de](mailto:Technischerdienst@gtue.de)  
Tel.: 0711-97676 510  
Fax.: 0711-97676 519

  
Dipl.-Ing. Andreas Kohlhas



**Prüfbericht**  
**Nr.: GTÜ StVZO22-14003.02**  
**zur Beantragung eines Nachtrags zur ABE Nr. KBA 91325\*02**  
**nach § 22 StVZO Austausch-Lenkungsdämpfer für Krafträder**



Fahrzeugteilarart : Lenkungsdämpfer für Krafträder  
 Typ : DS  
 Antragsteller : Hyper Pro Sales B.V., NL-4251 LR Werkendam

**Anlage 1**

Fahrzeug Hersteller	Fahrzeug Handelsbezeichnung	TYP	EG-BE / ABE	Baujahr	Ausführung	Hub	Montage
APRILIA (I)	RS 250	LD 01	G 897	'95 - '97	MK-AP02-S001	140	Kit left on Deltaframe
	RS 250	LD 01	G 897	'98 - '00	MK-AP02-S002	160	Kit left on Deltaframe
	RSV Mille	ME	H 827	'98 - '00	MK-AP10-O001	75	Mounting Kit in front of tripleclamp
	RSV Mille	RP	e11*00027	'01 - '03	MK-AP10-O002	75	Mounting Kit in front of tripleclamp
	RSV Mille R	ME	H 827	'98 - '00	MK-AP10-O001	75	Mounting Kit in front of tripleclamp
	RSV Mille Tuono Fighter	RP	e11*00027	'01 - '05	MK-AP10-O002	75	Mounting Kit in front of tripleclamp
	RSV 1000 R	RR	e11*0093	'04 - '05	MK-AP10-O003	75	Mounting Kit in front of tripleclamp
	RSV 1000 (Showa)	RR	e11*0093	'04 - '05	MK-AP10-O004	75	Mounting Kit in front of tripleclamp
	RSV 1000 (Ohlins)	RR	e11*0093	'06 - '08	MK-AP10-O005	75	Mounting Kit on original place
	RSV 4 R	RK	e11*0749	'09 ->	MK-AP10-O007	75	Mounting Kit in front of tripleclamp
	SL 750 Shiver	RA	e11*0619	'08 - '09	MK-AP07-T001	75	Mounting Kit in front of tripleclamp
BELGARDA (I)	Yamaha NSR 1100 (BT 1100 Bulldog)	RP 05	e1*00116	'02 - '03	MK-YA11-S001	160	Mounting Kit left on frame
BMW (D)	F 800 R	E 8 ST	e1*0283	'07 - '09	MK-BM08-O001	75	Mounting Kit on original place
	F 800 S	E 8 ST	e1*0283	'07 - '09	MK-BM08-O001	75	Mounting Kit on original place
	F 800 ST	E 8 ST	e1*0283	'07 - '09	MK-BM08-O001	75	Mounting Kit on original place
	K 1200 GT	K 12	e1*00104	'01 - '02	MK-BM12-O001	75	Mounting Kit on original place
	K 1200 GT	K 12	e1*0104	'02 - '03	MK-BM12-O001	75	Mounting Kit on original place
	K 1200 LT	K 2 LT	e1*00019	'99 - '08	MK-BM12-O001	75	Mounting Kit on original place
	K 1200 RS	BMW 589	H 646	'97 - '00	MK-BM12-O001	75	Mounting Kit on original place
	K 1200 RS	K 12	e1*00104	'01 - '02	MK-BM12-O001	75	Mounting Kit on original place
	K 1200 RS	K 12	e1*0104	'02 - '03	MK-BM12-O001	75	Mounting Kit on original place

**Prüfbericht**  
**Nr.: GTÜ StVZO22-14003.02**  
**zur Beantragung eines Nachtrags zur ABE Nr. KBA 91325\*02**  
**nach § 22 StVZO Austausch-Lenkungsdämpfer für Krafträder**



Fahrzeugteilart : Lenkungsdämpfer für Krafträder  
 Typ : DS  
 Antragsteller : Hyper Pro Sales B.V., NL-4251 LR Werkendam

**Anlage 1**

Fahrzeug Hersteller	Fahrzeug Handelsbezeichnung	TYP	EG-BE / ABE	Baujahr	Ausführung	Hub	Montage
	R 850 R	BMW 259	G 239	'94 - '01	MK-BM11-O001	75	Mounting Kit on original place
	R 1100 R	BMW 259	G 239	'95 - '00	MK-BM11-O001	75	Mounting Kit on original place
	R 1100 S	R 2 S	K 083	'98 - '01	MK-BM11-O001	75	Mounting Kit on original place
	R 1100 S	R 2 S	e1*00102	'01 - '04	MK-BM11-B001	75	Mounting Kit under low. tripleclamp
	R 1100 S	R 11 S	e1*0210	'04 - '06	MK-BM11-B001	75	Mounting Kit under low. tripleclamp
	R 1100 S Boxer Cup Replica	R 2 S	e1*00102	'03 - '04	MK-BM11-B001	75	Mounting Kit under low. tripleclamp
	R 1100 S Boxer Cup Replica	R 11 S	e1*0210	'04 - '06	MK-BM11-B001	75	Mounting Kit under low. tripleclamp
	R 1150 R	R 21	e1*00041	'01 - '04	MK-BM11-O001	75	Mounting Kit on original place
	R 1150 R	R 11 R	e1*0216	'04 - '06	MK-BM11-O001	75	Mounting Kit on original place
	R 1150 R Rockster	R 21	e1*00041	'02 - '04	MK-BM11-O001	75	Mounting Kit on original place
	R 1150 R Rockster	R 11 R	e1*0216	'04 - '06	MK-BM11-O001	75	Mounting Kit on original place
	R 1200 GS	R 12	e1*0199	'04 - '12	MK-BM12-B002	75	Mounting Kit under telelever
	R 1200 GS	R 12 W	e1*0584	'13	MK-BM12-B004	75	Mounting Kit under telelever
	R 1200 GS	R 12 W	e1*0584	'13	MK-BM12-B005	75	Mounting Kit under telelever
	R 1200 GS	R 12 W	e1*0584	'14 ->	MK-BM12-O004	68	Mounting Kit under telelever
	R 1200 GS Adventure	R 12	e1*0199	'04 - '12	MK-BM12-B002	75	Mounting Kit under telelever
	R 1200 R	R 1 ST	e1*0230	'06 - '08	MK-BM12-O002	75	Mounting Kit on original place
	R 1200 R	R 1 ST	e1*0230	'06 ->	MK-BM12-B003	75	Mounting Kit under telelever
	R 1200 RT	R 12 T	e1*0228	'04 - '11	MK-BM12-B003	75	Mounting Kit under telelever
	R 1200 RT	R 12 WT	e1*0613	'14 ->	MK-BM12-O004	68	Mounting Kit under telelever
	R 1200 S	R 12 S	e1*0284	'06 - '08	MK-BM12-O002	75	Mounting Kit on original place



**Prüfbericht**  
**Nr.: GTÜ StVZO22-14003.02**  
**zur Beantragung eines Nachtrags zur ABE Nr. KBA 91325\*02**  
**nach § 22 StVZO Austausch-Lenkungsdämpfer für Krafträder**



Fahrzeugteilart : Lenkungsdämpfer für Krafträder  
 Typ : DS  
 Antragsteller : Hyper Pro Sales B.V., NL-4251 LR Werkendam

**Anlage 1**

Fahrzeug Hersteller	Fahrzeug Handelsbezeichnung	TYP	EG-BE / ABE	Baujahr	Ausführung	Hub	Montage
	R Nine T	K 21	e1*0230	'14 ->	MK-BM12-O005	75	Mounting Kit on original place
	S 1000 RR	K 10	e1*0421	'09 - '12	MK-BM10-O001	75	Mounting Kit on original place
BUELL (USA)	Cyclone M 2	EB 1	H 657	'97 - '02	MK-BU12-S001	140	Mounting Kit left on frametube
	Cyclone M 2-2	EB 1	H 657	'97 - '02	MK-BU12-S001	140	Mounting Kit left on frametube
	Firebolt XB 9 R	XB 1	e4*0139	'03 - '04	MK-BU12-S004	140	Mounting Kit right on frametube
	Firebolt XB 9 R	XB 1	e4*0139	'05 - '07	MK-BU12-S005	140	Mounting Kit right on frametube
	Firebolt XB 12 R	XB 1	e4*0139	'03 - '04	MK-BU12-S004	140	Mounting Kit right on frametube
	Firebolt XB 12 R	XB 1	e4*0139	'05 - '07	MK-BU12-S005	140	Mounting Kit right on frametube
	Lightning S 1	EB 1	H 657	'97 - '02	MK-BU12-S001	140	Mounting Kit left on frametube
	Lightning S 1-2	EB 1	H 657	'97 - '02	MK-BU12-S001	140	Mounting Kit left on frametube
	Lightning X 1	BL 1	e1*00006	'98 - '02	MK-BU12-S003	120	Mounting Kit left on frametube
	Lightning X 1 Millenium	BL 1	e1*00006	'00 - '02	MK-BU12-S003	120	Mounting Kit left on frametube
	Lightning XB 9 S	XB 1	e4*0139	'03 - '04	MK-BU12-S004	140	Mounting Kit right on frametube
	Lightning XB 9 S	XB 1	e4*0139	'05 - '07	MK-BU12-S005	140	Mounting Kit right on frametube
	Lightning XB 12 S	XB 1	e4*0139	'03 - '04	MK-BU12-S004	140	Mounting Kit right on frametube
	Lightning XB 12 S	XB 1	e4*0139	'05 - '07	MK-BU12-S005	140	Mounting Kit right on frametube
	Lightning XB 12 Ss	XB 2	e4*0450	'06 - '07	MK-BU12-S005	140	Mounting Kit right on frametube
	Lightning XB 12 Ss Long	XB 2	e4*0450	'06 - '09	MK-BU12-S005	140	Mounting Kit right on frametube
	Ulysses XB 12 X	XB 2	e4*0450	'05 - '07	MK-BU12-S005	140	Mounting Kit right on frametube
	Thunderbolt S 3	EB 1	H 657	'96 - '02	MK-BU12-S001	140	Mounting Kit left on frametube
	Thunderbolt S 3-2	EB 1	H 657	'97 - '02	MK-BU12-S001	140	Mounting Kit left on frametube
	White Lightning S1 W-2	EB 1	H 657	'97 - '02	MK-BU12-S001	140	Mounting Kit left on frametube
White Lightning S1 W-2C	EB 1	H 657	'99 - '02	MK-BU12-S001	140	Mounting Kit left on frametube	
White Lightning S1 W-2D	EB 1	H 657	'98 - '02	MK-BU12-S001	140	Mounting Kit left on frametube	
X 1125 R	XB 3	e4*1455	'08 - '09	MK-BU11-C001	75	Mounting Kit on cockpit frame	

**Prüfbericht**  
**Nr.: GTÜ StVZO22-14003.02**  
**zur Beantragung eines Nachtrags zur ABE Nr. KBA 91325\*02**  
**nach § 22 StVZO Austausch-Lenkungsdämpfer für Krafträder**



Fahrzeugteilarart : Lenkungsdämpfer für Krafträder  
 Typ : DS  
 Antragsteller : Hyper Pro Sales B.V., NL-4251 LR Werkendam

**Anlage 1**

Fahrzeug Hersteller	Fahrzeug Handelsbezeichnung	TYP	EG-BE / ABE	Baujahr	Ausführung	Hub	Montage
DUCATI (I)	400 Super Sport Junior	ZDM 400 J	-	'92 - '95	MK-DU07-S002	140	Mounting Kit left on upp. frametube
	600 Super Sport Carenata	ZDM 600 S	-	'91 - '94	MK-DU07-S003	120	Mounting Kit left on upp. frametube
	600 Super Sport Carenata	S	G 801	'94 - '98	MK-DU07-S003	120	Mounting Kit left on upp. frametube
	600 Super Sport Nuda	ZDM 600 S	-	'91 - '94	MK-DU07-S002	140	Mounting Kit left on upp. frametube
	600 Super Sport Nuda	S	G 801	'94 - '98	MK-DU07-S002	140	Mounting Kit left on upp. frametube
	620 Super Sport i.E.	V 5	e3*0142	'02 - '07	MK-DU09-S001	140	Mounting Kit left on upp. frametube
	748	H 3	e1*00037	'99 - '02	MK-DU07-T001	75	Mounting Kit top/tank replace original
	748 Biposto	748	H 199	'95 - '99	MK-DU07-T001	75	Mounting Kit top/tank replace original
	748 S	748	H 199	'95 - '99	MK-DU07-T001	75	Mounting Kit top/tank replace original
	748 SP	748	-	'95 - '99	MK-DU07-T001	75	Mounting Kit top/tank replace original
	748 R	H 3	e1*00037	'00 - '03	MK-DU07-T001	75	Mounting Kit top/tank replace original
	749	H 5	e3*0153	'02 - '07	MK-DU07-T002	75	Mounting Kit top/tank replace original
	749 S	H 5	e3*0153	'02 - '07	MK-DU07-T002	75	Mounting Kit top/tank replace original
	750 Super Sport Carenata	ZDM 750 SC	-	'91 - '94	MK-DU07-S003	120	Mounting Kit left on upp. frametube
	750 Super Sport Carenata	S	G 801	'95 - '98	MK-DU07-S003	120	Mounting Kit left on upp. frametube
	750 Super Sport Nuda	ZDM 750 SC	-	'91 - '94	MK-DU07-S002	140	Mounting Kit left on upp. frametube
	750 Super Sport Nuda	S	G 801	'95 - '98	MK-DU07-S002	140	Mounting Kit left on upp. frametube
	750 Super Sport i.E.	V 2	e1*00026	'98 - '02	MK-DU09-S001	140	Mounting Kit left on upp. frametube
	800 Super Sport i.E.	V 5	e3*0142	'02 - '07	MK-DU09-S001	140	Mounting Kit left on upp. frametube
	848	H 6	e3*0475	'08 - '10	MK-DU08-T001	75	Mounting Kit top/tank
	848 S	H 6	e3*0475	'07 - '08	MK-DU08-T001	75	Mounting Kit top/tank
	848 EVO	H 6	e3*0475	'11 ->	MK-DU10-T002	75	Mounting Kit top/tank replace original
	851 S	ZDM 851 S	-	'88 - '90	MK-DU08-S002	120	Mounting Kit left on upp. frametube
	851 S	ZDM 851 S	-	'91 - '92	MK-DU08-S001	120	Mounting Kit left on upp. frametube
	851 SP 2	ZDM 851 S	-	'91 - '92	MK-DU08-S001	120	Mounting Kit left on upp. frametube

**Prüfbericht**  
**Nr.: GTÜ StVZO22-14003.02**  
**zur Beantragung eines Nachtrags zur ABE Nr. KBA 91325\*02**  
**nach § 22 StVZO Austausch-Lenkungsdämpfer für Krafträder**



Fahrzeugteilarart : Lenkungsdämpfer für Krafträder  
 Typ : DS  
 Antragsteller : Hyper Pro Sales B.V., NL-4251 LR Werkendam

**Anlage 1**

Fahrzeug Hersteller	Fahrzeug Handelsbezeichnung	TYP	EG-BE / ABE	Baujahr	Ausführung	Hub	Montage
	851 SP 3	ZDM 851 S	-	'92 - '93	MK-DU08-S001	120	Mounting Kit left on upp. frametube
	888 S	ZDM 888 S	-	'93 - '95	MK-DU08-S001	120	Mounting Kit left on upp. frametube
	888 SP 4	ZDM 888 S	-	'93 - '95	MK-DU08-S001	120	Mounting Kit left on upp. frametube
	888 SP 5	ZDM 888 S	-	'94 - '95	MK-DU08-S001	120	Mounting Kit left on upp. frametube
	900 Super Sport Carenata	ZDM 906 SC 2	-	'91 - '94	MK-DU07-S003	120	Mounting Kit left on upp. frametube
	900 Super Sport Carenata	S	G 801	'95 - '98	MK-DU07-S003	120	Mounting Kit left on upp. frametube
	900 Super Sport Nuda	ZDM 906 SC 2	-	'91 - '94	MK-DU07-S002	140	Mounting Kit left on upp. frametube
	900 Super Sport Nuda	S	G 801	'95 - '98	MK-DU07-S002	140	Mounting Kit left on upp. frametube
	900 Super Sport i.E.	V 1	e1*00004	'98 - '02	MK-DU09-S001	140	Mounting Kit left on upp. frametube
	900 Super Light	ZDM 906 SC2/3	-	'93 - '94	MK-DU07-S002	140	Mounting Kit left on upp. frametube
	900 Super Light	S	G 801	'94 - '98	MK-DU07-S002	140	Mounting Kit left on upp. frametube
	916 Biposto	916	G 846	'94 - '98	MK-DU07-T001	75	Mounting Kit top/tank replace original
	916 S	916	-	'93 - '98	MK-DU07-T001	75	Mounting Kit top/tank replace original
	916 S	916	G 846	'94 - '98	MK-DU07-T001	75	Mounting Kit top/tank replace original
	916 Strada	916	G 846	'94 - '98	MK-DU07-T001	75	Mounting Kit top/tank replace original
	916 SP	916	-	'93 - '98	MK-DU07-T001	75	Mounting Kit top/tank replace original
	916 SPS	H 1	-	'97 - '00	MK-DU07-T001	75	Mounting Kit top/tank replace original
	996	H 2	e1*00012	'97 - '01	MK-DU07-T001	75	Mounting Kit top/tank replace original
	996 Biposto	H 2	e1*00012	'98 - '01	MK-DU07-T001	75	Mounting Kit top/tank replace original
	996 R	H 2	e1*00012	'00 - '02	MK-DU07-T001	75	Mounting Kit top/tank replace original
	996 S	H 2	e1*00012	'00 - '02	MK-DU07-T001	75	Mounting Kit top/tank replace original
	996 SPS	H 1	e1*00096	'98 - '02	MK-DU07-T001	75	Mounting Kit top/tank replace original
	998 Biposto	H 2	e1*00012	'01 - '04	MK-DU07-T001	75	Mounting Kit top/tank replace original
	998 R	H 2	e1*00012	'01 - '04	MK-DU07-T001	75	Mounting Kit top/tank replace original
	998 S	H 2	e1*00012	'01 - '04	MK-DU07-T001	75	Mounting Kit top/tank replace original

**Prüfbericht**  
**Nr.: GTÜ StVZO22-14003.02**  
**zur Beantragung eines Nachtrags zur ABE Nr. KBA 91325\*02**  
**nach § 22 StVZO Austausch-Lenkungsdämpfer für Krafträder**



Fahrzeugteilarart : Lenkungsdämpfer für Krafträder  
 Typ : DS  
 Antragsteller : Hyper Pro Sales B.V., NL-4251 LR Werkendam

**Anlage 1**

Fahrzeug Hersteller	Fahrzeug Handelsbezeichnung	TYP	EG-BE / ABE	Baujahr	Ausführung	Hub	Montage
	999	H 4	e3*0147	'02 - '07	MK-DU07-T002	75	Mounting Kit top/tank replace original
	999 S	H 4	e3*0147	'02 - '07	MK-DU07-T002	75	Mounting Kit top/tank replace original
	1000 Paul Smart Replica	C 1	e3*0343	'05 - '11	MK-DU10-T003	75	Mounting Kit top/tank replace original
	1000 Sport Classic	C 1	e3*0343	'05 - '11	MK-DU10-S002	140	Mounting Kit left/right on frame
	1000 Sport S	C 1	e3*0343	'06 - '11	MK-DU10-T003	75	Mounting Kit top/tank replace original
	1000 Super Sport i.E.	V 5	e3*0142	'05 - '07	MK-DU10-S001	140	Mounting Kit left on upp. frametube
	1098	H 7	e3*0436	'06 - '08	MK-DU10-T002	75	Mounting Kit top/tank replace original
	1098 S	H 7	e3*0436	'06 - '08	MK-DU10-T002	75	Mounting Kit top/tank replace original
	1198	H 7	e3*0436	'09 - '11	MK-DU10-T002	75	Mounting Kit top/tank replace original
	1198 S	H 7	e3*0436	'09 - '11	MK-DU10-T002	75	Mounting Kit top/tank replace original
	1199 Panigale	H 8	e3*0586	'12 ->	MK-DU12-O001	75	Mounting Kit top/tank replace original
	Hypermotard 1100	B 1	e3*0458	'07 - '10	MK-DU10-T002	75	Mounting Kit top/tank replace original
	Hypermotard 1100 S	B 1	e3*0458	'07 - '10	MK-DU10-T002	75	Mounting Kit top/tank replace original
	M 400 Monster	ZDM 400 M	-	'94	MK-DU04-S001	140	Mounting Kit on upp. frametube
	M 400 Monster	ZDM 400 M	-	'94	MK-DU04-S002	140	Mounting Kit on low. frametube
	M 400 Monster	M 3	e1*00025	'98 - '01	MK-DU04-S001	140	Mounting Kit on upp. frametube
	M 400 Monster	M 3	e1*00025	'98 - '01	MK-DU04-S002	140	Mounting Kit on low. frametube
	M 400 Monster i.E.	M 4	e3*0281	'06 - '07	MK-DU04-S003	140	Mounting Kit left/right on frame
	M 600 Monster	ZDM 600 M	-	'94	MK-DU04-S001	140	Mounting Kit on upp. frametube
	M 600 Monster	ZDM 600 M	-	'94	MK-DU04-S002	140	Mounting Kit on low. frametube
	M 600 Monster	M 3	e1*00025	'98 - '01	MK-DU04-S001	140	Mounting Kit on upp. frametube
	M 600 Monster	M 3	e1*00025	'98 - '01	MK-DU04-S002	140	Mounting Kit on low. frametube
	M 600 Monster	M	G 802	'94 - '97	MK-DU04-S001	140	Mounting Kit on upp. frametube
	M 600 Monster	M	G 802	'94 - '97	MK-DU04-S002	140	Mounting Kit on low. frametube
	M 620 Monster i.E.	M 4	e3*0030	'01 - '05	MK-DU04-S003	140	Mounting Kit left/right on frame

**Prüfbericht**  
**Nr.: GTÜ StVZO22-14003.02**  
**zur Beantragung eines Nachtrags zur ABE Nr. KBA 91325\*02**  
**nach § 22 StVZO Austausch-Lenkungsdämpfer für Krafträder**



Fahrzeugteilarart : Lenkungsdämpfer für Krafträder  
 Typ : DS  
 Antragsteller : Hyper Pro Sales B.V., NL-4251 LR Werkendam

**Anlage 1**

Fahrzeug Hersteller	Fahrzeug Handelsbezeichnung	TYP	EG-BE / ABE	Baujahr	Ausführung	Hub	Montage
	M 620 Monster i.E.	M 4	e3*0281	'06	MK-DU04-S003	140	Mounting Kit left/right on frame
	M 620 Monster S i.E.	M 4	e3*0030	'01 - '05	MK-DU04-S003	140	Mounting Kit left/right on frame
	M 620 Monster S i.E.	M 4	e3*0281	'06	MK-DU04-S003	140	Mounting Kit left/right on frame
	M 695 Monster i.E.	M 4	e3*0281	'06 - '07	MK-DU04-S003	140	Mounting Kit left/right on frame
	M 696 Monster i.E.	M 5	e3*0281	'06 - '07	MK-DU06-T001	75	Mounting Kit top/tank
	M 750 Monster	M	G 802	'97 - '01	MK-DU04-S001	140	Mounting Kit on upp. frametube
	M 750 Monster	M	G 802	'97 - '01	MK-DU04-S002	140	Mounting Kit on low. frametube
	M 750 Monster	M 1	e1*00052	'99 - '02	MK-DU04-S001	140	Mounting Kit on upp. frametube
	M 750 Monster	M 1	e1*00052	'99 - '02	MK-DU04-S002	140	Mounting Kit on low. frametube
	M 750 Monster i.E.	M 4	e3*0281	'06 - '07	MK-DU04-S003	140	Mounting Kit left/right on frame
	M 750 Monster S i.E.	M 4	e3*0281	'06 - '07	MK-DU04-S003	140	Mounting Kit left/right on frame
	M 800 Monster i.E.	M 4	e3*0281	'06 - '07	MK-DU04-S003	140	Mounting Kit left/right on frame
	M 803 Monster S 2 R	M 4	e3*0281	'06 - '07	MK-DU04-S003	140	Mounting Kit left/right on frame
	M 900 Monster	ZDM 900 M	-	'93 - '94	MK-DU04-S001	140	Mounting Kit on upp. frametube
	M 900 Monster	ZDM 900 M	-	'93 - '94	MK-DU04-S002	140	Mounting Kit on low. frametube
	M 900 Monster	M	G 802	'94 - '99	MK-DU04-S001	140	Mounting Kit on upp. frametube
	M 900 Monster	M	G 802	'94 - '99	MK-DU04-S002	140	Mounting Kit on low. frametube
	M 900 Monster i.E.	M 2	e1*00051	'00 - '01	MK-DU04-S001	140	Mounting Kit on upp. frametube
	M 900 Monster i.E.	M 2	e1*00051	'00 - '01	MK-DU04-S002	140	Mounting Kit on low. frametube
	M 900 Monster S i.E.	M 2	e1*00051	'00 - '01	MK-DU04-S001	140	Mounting Kit on upp. frametube
	M 900 Monster S i.E.	M 2	e1*00051	'00 - '01	MK-DU04-S002	140	Mounting Kit on low. frametube
	M 916 Monster S 4	M 4	e3*0281	'06 - '07	MK-DU04-S003	140	Mounting Kit left/right on frame
	M 992 Monster i.E.	M 4	e3*0281	'06 - '07	MK-DU04-S003	140	Mounting Kit left/right on frame
	M 992 Monster S i.E.	M 4	e3*0281	'06 - '07	MK-DU04-S003	140	Mounting Kit left/right on frame
	M 996 Monster S 4 R	M 4	e3*0281	'06 - '07	MK-DU04-S003	140	Mounting Kit left/right on frame

**Prüfbericht**  
**Nr.: GTÜ StVZO22-14003.02**  
**zur Beantragung eines Nachtrags zur ABE Nr. KBA 91325\*02**  
**nach § 22 StVZO Austausch-Lenkungsdämpfer für Krafträder**



Fahrzeugteilarart : Lenkungsdämpfer für Krafträder  
 Typ : DS  
 Antragsteller : Hyper Pro Sales B.V., NL-4251 LR Werkendam

**Anlage 1**

Fahrzeug Hersteller	Fahrzeug Handelsbezeichnung	TYP	EG-BE / ABE	Baujahr	Ausführung	Hub	Montage
	M 996 Monster S 4 RS	M 4	e3*0281	'06 - '07	MK-DU04-S003	140	Mounting Kit left/right on frame
	M 998 Monster S 4 RS	M 4	e3*0281	'06 - '07	MK-DU04-S003	140	Mounting Kit left/right on frame
	M 1100 Monster i.E.	M 5	e3*0281	'06 - '07	MK-DU06-T001	75	Mounting Kit top/tank
	M 1100 Monster S i.E	M 5	e3*0281	'06 - '07	MK-DU06-T001	75	Mounting Kit top/tank
	MH 900 evoluzione	V 3	e3*0046	'00 - '03	MK-DU09-O001	75	Mounting Kit on original place
HARLEY DAVIDSON (USA)	XL 883	XL 2	e4*0208	'04 - '06	MK-HD12-S002	120	Mounting Kit left on frametube
	XLH 883	XL 1	e4*0028	'99 - '01	MK-HD12-S001	160	Mounting Kit left on frametube
	XLH 883 Sportster	XL/2	C 560	'97 - '99	MK-HD12-S001	160	Mounting Kit left on frametube
	XL 1200 R Sportster	XL 2	e4*0208	'04 ->	MK-HD12-S002	120	Mounting Kit left on frametube
	XL 1200 S Sport	XL/2	C 560	'98 - '99	MK-HD12-S001	160	Mounting Kit left on frametube
	XL 1200 S Sport	XL 1	e4*0028	'00 - '03	MK-HD12-S001	160	Mounting Kit left on frametube
	XR 1200	XR 1	e4*1789	'08 ->	MK-HD12-S003	120	Mounting Kit right on frame
	XR 1200 X	XR 1	e4*1789	'09 ->	MK-HD12-S003	120	Mounting Kit right on frame
HONDA ITALIA (I)	CB 600 F Hornet	PC 36	e3*0101	'02 - '06	MK-HO06-S004	160	Mounting Kit left on engine/frame
	CB 600 S Hornet	PC 36	e3*0101	'02 - '06	MK-HO06-S004	160	Mounting Kit left on engine/frame
	CB 600 F Hornet	PC 41	e3*0454	'07 - '08	MK-HO06-T009	75	Mounting Kit top/tank
	CB 1000 R	SC 60	e4*1912	'08 ->	MK-HO10-T007	75	Mounting Kit top/tank
	CB 1000 R	SC 60	e4*1912	'08 ->	MK-HO10-T008	75	Mounting Kit top/tank
	CB 1000 RA	SC 60	e4*1912	'08 ->	MK-HO10-T007	75	Mounting Kit top/tank
Honda (J)	CB 600 F Hornet	PC 34	K 016	'98 - '01	MK-HO06-S004	160	Mounting Kit left on engine/frame
	CB 600 F Hornet	PC 34	e13*0020	'01 - '02	MK-HO06-S004	160	Mounting Kit left on engine/frame
	CB 600 S Hornet	PC 34	K 016	'99 - '01	MK-HO06-S004	160	Mounting Kit left on engine/frame
	CB 600 S Hornet	PC 34	e13*0020	'01 - '02	MK-HO06-S004	160	Mounting Kit left on engine/frame
	CBR 600 F	PC 25	F 648	'91 - '93	MK-HO06-T001	75	Mounting Kit top/tank
	CBR 600 F	PC 31	H 002	'94 - '96	MK-HO06-T001	75	Mounting Kit top/tank

**Prüfbericht**  
**Nr.: GTÜ StVZO22-14003.02**  
**zur Beantragung eines Nachtrags zur ABE Nr. KBA 91325\*02**  
**nach § 22 StVZO Austausch-Lenkungsdämpfer für Krafträder**



Fahrzeugteilarart : Lenkungsdämpfer für Krafträder  
 Typ : DS  
 Antragsteller : Hyper Pro Sales B.V., NL-4251 LR Werkendam

**Anlage 1**

Fahrzeug Hersteller	Fahrzeug Handelsbezeichnung	TYP	EG-BE / ABE	Baujahr	Ausführung	Hub	Montage
	CBR 600 F	PC 35	K 294	'97 - '98	MK-HO06-T001	75	Mounting Kit top/tank
	CBR 600 F	PC 35	K 294	'99 - '00	MK-HO06-T005	75	Mounting Kit top/tank
	CBR 600 F	PC 35	e4*0101	'01 - '02	MK-HO06-T005	75	Mounting Kit top/tank
	CBR 600 FS	PC 35	e4*0101	'01 - '02	MK-HO06-T005	75	Mounting Kit top/tank
	CBR 600 RR	PC 37	e4*0190	'03 - '04	MK-HO06-T006	75	Mounting Kit top/tank
	CBR 600 RR	PC 37	e4*0190	'05 - '06	MK-HO06-T007	75	Mounting Kit top/tank
	CBR 600 RR	PC 40	e4*1247	'07 - '10	MK-HO06-T008	75	Mounting Kit top/tank
	CBR 600 RR	PC 40	e4*1247	'07 - '10	MK-HO06-S005	120	Mounting Kit right on frame
	CBR 900 RR	SC 28	G 034	'92 - '95	MK-HO09-T001	75	Mounting Kit top/tank
	CBR 900 RR	SC 29	-	'92 - '95	MK-HO09-T001	75	Mounting Kit top/tank
	CBR 900 RR	SC 33	H 294	'96 - '99	MK-HO09-T002	75	Mounting Kit top/tank
	CBR 900 RR	SC 44	e13*0019	'00 - '01	MK-HO09-T004	75	Mounting Kit top/tank
	CBR 900 RR	SC 50	e13*0052	'02 - '03	MK-HO09-T005	75	Mounting Kit top/tank
	CBR 1000 RR	SC 57	e4*0269	'04 - '07	MK-HO10-T004	75	Mounting Kit top/tank
	CBR 1000 RR	SC 59	e4*1726	'08 - '10	MK-HO10-T006	75	Mounting Kit top/tank
	ST 1300 Pan European	SC 51	e1*0147	'02 ->	MK-HO13-B001	75	Mounting Kit under low. tripleclamp
	VTR 1000 F	SC 36	H 687	'97 - '01	MK-HO10-T005	75	Mounting Kit top/tank
	VTR 1000 F	SC 36	e13*0044	'01 - '05	MK-HO10-T005	75	Mounting Kit top/tank
	VTR 1000 SP-1	SC 45	e4*0061	'00 - '01	MK-HO10-T002	75	Mounting Kit top/tank
	VTR 1000 SP-2	SC 45	e4*0061	'02 - '05	MK-HO10-T003	75	Mounting Kit top/tank
Kawasaki (J)	300R Ninja	EX250K	e1*0351	'13 ->	MK-KA03-T001	75	Mounting Kit top/tank
	300R Ninja	EX250H	e1*00076*02	'13 ->	MK-KA03-T001	75	Mounting Kit top/tank
	ER-6 f ABS	EX 650 C	e1*0417	'09 - '11	MK-KA06-T007	75	Mounting Kit top/tank
	ER-6 n ABS	ER 650 C	e1*0409	'09 - '11	MK-KA06-T007	75	Mounting Kit top/tank
	ER-6 n	EX 650 C	e1*0417	'12 ->	MK-KA06-T008	75	Mounting Kit top/tank

**Prüfbericht**  
**Nr.: GTÜ StVZO22-14003.02**  
**zur Beantragung eines Nachtrags zur ABE Nr. KBA 91325\*02**  
**nach § 22 StVZO Austausch-Lenkungsdämpfer für Krafträder**



Fahrzeugteilarart : Lenkungsdämpfer für Krafträder  
 Typ : DS  
 Antragsteller : Hyper Pro Sales B.V., NL-4251 LR Werkendam

**Anlage 1**

Fahrzeug Hersteller	Fahrzeug Handelsbezeichnung	TYP	EG-BE / ABE	Baujahr	Ausführung	Hub	Montage
	ER-6 n	ER 650 A	e1*0260	'12 ->	MK-KA06-T008	75	Mounting Kit top/tank
	ER-6 n	ER 650 C	e1*0409	'12 ->	MK-KA06-T008	75	Mounting Kit top/tank
	Versys 650 (auch ABS)	LE 650 A	e1*0305	'07 ->	MK-KA06-B008	75	Mounting Kit under low. tripleclamp
	Versys 650 (auch ABS)	LE 650 C	e1*0462	'07 ->	MK-KA06-B008	75	Mounting Kit under low. tripleclamp
	Versys 650 (auch ABS)	LE 650 E	e1*0653	'15 ->	MK-KA06-B009	75	Mounting Kit under low. tripleclamp
	Versys 1000	WVBS	e4*0142	'12 ->	MK-KA10-B009	75	Mounting Kit under low. tripleclamp
	Z 750	ZR 750 J	e1*0197	'03 - '06	MK-KA10-T005	75	Mounting Kit top/tank
	Z 750	ZR 750 L	e1*0309	'06 ->	MK-KA10-T005	75	Mounting Kit top/tank
	Z 750 R	ZR 750 L	e1*0309	'06 ->	MK-KA10-T005	75	Mounting Kit top/tank
	Z 750 S	ZR 750 J	e1*0197	'05 - '06	MK-KA10-T005	75	Mounting Kit top/tank
	Z 800	ZR 800 A	e4*2908	'13 ->	MK-KA08-T001	75	Mounting Kit top/tank
	Z 1000	ZRT 00 A	e1*0172	'03 - '06	MK-KA10-T005	75	Mounting Kit top/tank
	Z 1000	ZRT 00 B	e1*0172	'07 - '09	MK-KA10-T005	75	Mounting Kit top/tank
	Z 1000	ZRT 00 D	e4*2374	'10 ->	MK-KA10-T008	75	Mounting Kit top/tank
	Z 1000	KZT00J	C048	'10 ->	MK-KA10-T008	75	Mounting Kit top/tank
	Z 1000	ZRT 00 F	e4*3009	'14 ->	MK-KA10-T009	75	Mounting Kit top/tank
	ZRX 1100	ZRT 10 C	H 619	'96 - '98	MK-KA11-S001	75	Mounting Kit under low. tripleclamp
	ZRX 1100	ZRT 10 C	e4*0011	'97 - '00	MK-KA12-B002	75	Mounting Kit under low. tripleclamp
	ZRX 1200	ZRT 20 A	e4*0106	'01 ->	MK-KA12-B002	75	Mounting Kit under low. tripleclamp
	ZRX 1200 R	ZRT 20 A	e4*0106	'01 ->	MK-KA12-B002	75	Mounting Kit under low. tripleclamp
	ZRX 1200 S	ZRT 20 A	e4*0106	'01 ->	MK-KA12-B002	75	Mounting Kit under low. tripleclamp
	ZRX 1200 DAEG	ZRT 20 A	e4*0106	'01 ->	MK-KA12-B002	75	Mounting Kit under low. tripleclamp
	ZX-6 R Ninja	ZX 600 F	G 937	'95 - '97	MK-KA06-T001	75	Mounting Kit top/tank
	ZX-6 R Ninja	ZX 600 G	H 967	'98 - '99	MK-KA06-T002	75	Mounting Kit top/tank
	ZX-6 R Ninja	ZX 600 J	e4*0042	'00 - '02	MK-KA06-T003	75	Mounting Kit top/tank



**Prüfbericht**  
**Nr.: GTÜ StVZO22-14003.02**  
**zur Beantragung eines Nachtrags zur ABE Nr. KBA 91325\*02**  
**nach § 22 StVZO Austausch-Lenkungsdämpfer für Krafträder**



Fahrzeugteilarart : Lenkungsdämpfer für Krafträder  
 Typ : DS  
 Antragsteller : Hyper Pro Sales B.V., NL-4251 LR Werkendam

**Anlage 1**

Fahrzeug Hersteller	Fahrzeug Handelsbezeichnung	TYP	EG-BE / ABE	Baujahr	Ausführung	Hub	Montage
	ZX-6 R Ninja	ZX 600 J	e4*0042	'00 - '02	MK-KA06-S003	140	Mounting Kit left on Deltaframe
	ZX-6 R Ninja	ZX 600 P	e4*1274	'07 - '08	MK-KA06-T006	75	Mounting Kit top/tank
	ZX-6 R Ninja	ZX 600 R	e4*2077	'09 - '12	MK-KA10-T006	75	Mounting Kit on original place
	ZX-6 R Ninja	ZX 636 A	e1*00141	'02 - '03	MK-KA06-T004	75	Mounting Kit top/tank
	ZX-6 R Ninja	ZX 636 B	e1*00141	'03 - '04	MK-KA06-T004	75	Mounting Kit top/tank
	ZX-6 R Ninja	ZX 636 C	e1*00141	'05 - '06	MK-KA06-T005	75	Mounting Kit top/tank
	ZX-6 RR Ninja	ZX 600 K	e1*00141	'03 - '05	MK-KA06-S004	140	Mounting Kit left on Deltaframe
	ZX-6 RR Ninja	ZX 600 N	e1*00141	'05 - '07	MK-KA06-S004	140	Mounting Kit left on Deltaframe
	ZX-7 R Ninja	ZX 750 N	H 202	'96 - '02	MK-KA07-T001	75	Mounting Kit top/tank
	ZX-9 R Ninja	ZX 900 B	G 588	'94 - '97	MK-KA09-T001	75	Mounting Kit top/tank
	ZX-9 R Ninja	ZX 900 C	H 884	'98 - '99	MK-KA09-T002	75	Mounting Kit top/tank
	ZX-9 R Ninja	ZX 900 E	e1*00054	'00 - '01	MK-KA09-T003	75	Mounting Kit top/tank
	ZX-9 R Ninja	ZX 900 E	e1*00054	'02 - '03	MK-KA09-T004	75	Mounting Kit top/tank
	ZX-9 R Ninja	ZX 900 E	e1*00054	'00 - '03	MK-KA09-S003	140	Mounting Kit left on Deltaframe
	ZX-10 R Ninja	ZXT 00 C	e4*0246	'04 - '05	MK-KA10-T001	75	Mounting Kit top/tank
	ZX-10 R Ninja	ZXT 00 C	e4*0246	'06 - '11	MK-KA10-T006	75	Mounting Kit top/tank
	ZX-10 R Ninja	ZXT 00 D	e1*0270	'06 - '07	MK-KA10-T006	75	Mounting Kit top/tank replace original
	ZX-10 R Ninja	ZXT 00 E	e1*0350	'06 - '11	MK-KA10-T006	75	Mounting Kit top/tank replace original
	ZX-10 R Ninja	ZXT 00 F	e1*0443	'06 - '11	MK-KA10-T006	75	Mounting Kit top/tank replace original
	ZX-10 R Ninja	ZXT 00 J	e4*2549	'06 - '11	MK-KA10-T006	75	Mounting Kit top/tank replace original
	ZX-12 R Ninja	ZXT 20 A	e1*00065	'00 - '01	MK-KA12-T001	75	Mounting Kit top/tank
	ZX-12 R Ninja	ZXT 20 A	e1*00065	'02 - '05	MK-KA12-T002	75	Mounting Kit top/tank
	ZX-250 R Ninja	EX 250 K	e1*0351	'07 - '08	MK-KA02-T001	75	Mounting Kit top/tank
	ZX-300 R Ninja	EX 300 A	e1*0572	'13 ->	MK-KA03-T001	75	Mounting Kit top/tank
	ZXR 400	ZX 400 L	F 669	'91 - '93	MK-KA04-S001	140	Mounting Kit left on Deltaframe

**Prüfbericht**  
**Nr.: GTÜ StVZO22-14003.02**  
**zur Beantragung eines Nachtrags zur ABE Nr. KBA 91325\*02**  
**nach § 22 StVZO Austausch-Lenkungsdämpfer für Krafträder**



Fahrzeugteilarart : Lenkungsdämpfer für Krafträder  
 Typ : DS  
 Antragsteller : Hyper Pro Sales B.V., NL-4251 LR Werkendam

**Anlage 1**

Fahrzeug Hersteller	Fahrzeug Handelsbezeichnung	TYP	EG-BE / ABE	Baujahr	Ausführung	Hub	Montage
	ZXR 400	ZX 400 H	-	'91 - '95	MK-KA04-S001	140	Mounting Kit left on Deltaframe
	ZXR 750	ZX 750 L	G 154	'92 - '95	MK-KA07-S001	140	Mounting Kit right on Deltaframe
	ZXR 750 R	ZX 750 L	G 154	'92 - '95	MK-KA07-S001	140	Mounting Kit right on Deltaframe
	ZZR 1200	ZXT 20 C	e1*00142	'02 - '05	MK-KA12-T003	75	Mounting Kit top/tank
	ZZR 1400	ZXT 40 A	e4*0912	'06	MK-KA14-T001	75	Mounting Kit top/tank
	ZZR 1400	ZXT 40 C	e4*1560	'07 ->	MK-KA14-T001	75	Mounting Kit top/tank
KTM (A)	990 LC 8 Super Duke	KTM LC8 EFI	e1*0232	'04 - '06	MK-KT09-T001	75	Mounting Kit top/tank
	990 LC 8 Super Duke	KTM LC8 EFI	e1*0232	'07 - '09	MK-KT09-T001	75	Mounting Kit top/tank
	1190 RC 8	KTM RC8	e1*0379	'08 ->	MK-KT11-T001	75	Mounting Kit top/tank
	1190 Adventure	KTM Adventure	e1*0596	'13 ->	MK-KT11-B001	75	Mounting Kit on original place
MOTO GUZZI (I)	V 10 Centauro	KK	H 649	'98 - '00	MK-MG10-O001	75	Mounting Kit on original place
	V 11 Sport	KR	e3*0007	'98 - '00	MK-MG10-O001	75	Mounting Kit on original place
MOTO MORINI (I)	9 ½	01	e3*0340	'05 - '06	MK-MM12-S001	140	Mounting Kit left on Deltaframe
	Corsaro 1200	01	e3*0340	'05 - '06	MK-MM12-S001	140	Mounting Kit left on Deltaframe
	Corsaro 1200	02	e3*0443	'07 - '11	MK-MM12-S001	140	Mounting Kit left on Deltaframe
	Corsaro 1200 Avio	02	e3*0443	'07 - '11	MK-MM12-S001	140	Mounting Kit left on Deltaframe
	Corsaro 1200 Veloce	02	e3*0340	'08 - '11	MK-MM12-S001	140	Mounting Kit left on Deltaframe
MV Agusta (I)	F 4	F 4	e3*0024	'99 - '12	MK-MV10-T001	75	Mounting Kit on original place
PIAGGIO (I)	Aprilia RSV 1000 R (Öhlins)	RR	e11*0093	'06 - '08	MK-AP10-O005	75	Mounting Kit on original place
	Aprilia RSV 1000 R Tuono Fighter	RR	e11*0093	'06 ->	MK-AP10-O006	75	Mounting Kit in front of tripleclamp
	Aprilia SL 750 Shiver	RA	e11*0619	'08 - '10	MK-AP07-T001	75	Mounting Kit top/tank
	Aprilia Dorsoduro 750	SM	e11*0669	'08 ->	MK-AP07-T002	75	Mounting Kit top/tank
Suzuki (J)	GSX 1300 BK B-King	WVCR	e4*1531	'07 - '11	MK-SU13-O001	75	Mounting Kit top/tank
	GSX 1300 R Hayabusa	WVA 1	e4*0012	'99 - '05	MK-SU13-T003	75	Mounting Kit top/tank
	GSX 1300 R Hayabusa	WVA 1	e4*0852	'06 - '08	MK-SU13-T003	75	Mounting Kit top/tank

**Prüfbericht**  
**Nr.: GTÜ StVZO22-14003.02**  
**zur Beantragung eines Nachtrags zur ABE Nr. KBA 91325\*02**  
**nach § 22 StVZO Austausch-Lenkungsdämpfer für Krafträder**



Fahrzeugteilarart : Lenkungsdämpfer für Krafträder  
 Typ : DS  
 Antragsteller : Hyper Pro Sales B.V., NL-4251 LR Werkendam

**Anlage 1**

Fahrzeug Hersteller	Fahrzeug Handelsbezeichnung	TYP	EG-BE / ABE	Baujahr	Ausführung	Hub	Montage
	GSX 1300 R Hayabusa II	WVCK	e4*1618	'07 - '08	MK-SU13-T003	75	Mounting Kit top/tank
	GSX 1300 R Hayabusa II	WVCK	e4*1618	'08 - '11	MK-SU07-O002	75	Mounting Kit on original place
	GSX 1400	WVBN	e4*0116	'01 - '06	MK-SU14-B001	75	Mounting Kit under low. tripleclamp
	GSX-R 600	AD	H 583	'96 - '00	MK-SU06-T005	75	Mounting Kit top/tank
	GSX-R 600	WVBG	e4*0100	'00 - '03	MK-SU06-T004	75	Mounting Kit top/tank
	GSX-R 600	WVBG	e4*0100	'00 - '03	MK-SU07-O002	75	Mounting Kit on original place
	GSX-R 600	WVB 2	e4*0253	'04 - '05	MK-SU06-T006	75	Mounting Kit top/tank
	GSX-R 600	WVB 2	e4*0253	'04 - '05	MK-SU07-O002	75	Mounting Kit on original place
	GSX-R 600	WVCE	e4*0849	'06 - '07	MK-SU06-T009	75	Mounting Kit top/tank
	GSX-R 600	WVCE	e4*0849	'06 - '07	MK-SU07-O002	75	Mounting Kit on original place
	GSX-R 600	WVCV	e4*1756	'08 ->	MK-SU10-O002	75	Mounting Kit on original place
	GSX-R 750	WVBD	e4*0068	'99 - '03	MK-SU07-T002	75	Mounting Kit top/tank
	GSX-R 750	WVBD	e4*0068	'99 - '03	MK-SU07-O002	75	Mounting Kit on original place
	GSX-R 750	WVB 3	e4*0261	'04 - '05	MK-SU06-T006	75	Mounting Kit top/tank
	GSX-R 750	WVB 3	e4*0261	'04 - '05	MK-SU07-O002	75	Mounting Kit on original place
	GSX-R 750	WVCF	e4*0890	'06 - '07	MK-SU06-T009	75	Mounting Kit top/tank
	GSX-R 750	WVCF	e4*0890	'06 - '07	MK-SU07-O002	75	Mounting Kit on original place
	GSX-R 750	WVCW	e4*1852	'08 ->	MK-SU10-O002	75	Mounting Kit on original place
	GSX-R 750 FI	GR 7 DB	H 254	'97 - '99	MK-SU06-T005	75	Mounting Kit top/tank
	GSX-R 750 T	GR 7 DB	H 254	'95 - '98	MK-SU06-T005	75	Mounting Kit top/tank
	GSX-R 750 W	GR 7 BB	F 971	'92 - '93	MK-SU07-S001	160	Mounting Kit left on frame
	GSX-R 1000	WVBL	e4*0375	'01 - '02	MK-SU10-T003	75	Mounting Kit top/tank
	GSX-R 1000	WVBL	e4*0375	'01 - '02	MK-SU07-O002	75	Mounting Kit on original place
	GSX-R 1000	WVBZ	e4*0375	'03 - '04	MK-SU10-T005	75	Mounting Kit top/tank
	GSX-R 1000	WVBZ	e4*0375	'03 - '04	MK-SU07-O002	75	Mounting Kit on original place

**Prüfbericht**  
**Nr.: GTÜ StVZO22-14003.02**  
**zur Beantragung eines Nachtrags zur ABE Nr. KBA 91325\*02**  
**nach § 22 StVZO Austausch-Lenkungsdämpfer für Krafträder**



Fahrzeugteilarart : Lenkungsdämpfer für Krafträder  
 Typ : DS  
 Antragsteller : Hyper Pro Sales B.V., NL-4251 LR Werkendam

**Anlage 1**

Fahrzeug Hersteller	Fahrzeug Handelsbezeichnung	TYP	EG-BE / ABE	Baujahr	Ausführung	Hub	Montage
	GSX-R 1000	WVB 6	e4*0375	'05 - '06	MK-SU10-T006	75	Mounting Kit top/tank
	GSX-R 1000	WVB 6	e4*0375	'05 - '06	MK-SU07-O002	75	Mounting Kit on original place
	GSX-R 1000	WVCL	e4*1343	'07 - '08	MK-SU10-T007	75	Mounting Kit top/tank
	GSX-R 1000	WVCL	e4*1343	'07 - '08	MK-SU10-O002	75	Mounting Kit on original place
	GSX-R 1000	WVCY	e4*2132	'09 ->	MK-SU10-T009	75	Mounting Kit top/tank
	GSX-R 1000	WVCY	e4*2132	'09 ->	MK-SU10-O002	75	Mounting Kit on original place
	GSX-R 1100	GV 73 C	F 024	'89	MK-SU11-S001	160	Mounting Kit left on frame
	GSX-R 1100	GV 73 C	F 024	'90 - '92	MK-SU11-S002	160	Mounting Kit left on frame
	SFV 650 Gladius	WVCX	e4*2102	'08 ->	MK-SU06-T010	75	Mounting Kit top/tank
	SV 650	AV	K 329	'98 - '02	MK-SU06-T002	75	Mounting Kit top/tank
	SV 650	WVBY	e4*0192	'03 - '07	MK-SU06-B001	75	Mounting Kit under tripleclamp
	SV 650 S	AV	K 329	'98 - '02	MK-SU06-T003	75	Mounting Kit top/tank
	SV 650 S	WVBY	e4*0192	'03 - '07	MK-SU10-T004	75	Mounting Kit top/tank
	SV 1000	WVBX	e4*0191	'03 - '04	MK-SU10-O003	75	Mounting Kit on original place
	SV 1000 S	WVBX	e4*0191	'03 - '04	MK-SU10-O004	75	Mounting Kit on original place
	SV 1000 S	WVBX	e4*0191	'03 - '04	MK-SU10-T004	75	Mounting Kit top/tank
	TL 1000 R	AM	H 977	'98 - '99	MK-SU10-T001	75	Mounting Kit top/tank
	TL 1000 R	AM	H 977	'98 - '99	SM-SU10-O001	75	Mounting Kit top upp. tripleclamp
	TL 1000 S	AG	H 632	'97 - '01	MK-SU10-T008	75	Mounting Kit top/tank
Thai-Honda (J)	CBR 125 R	JC 34	e13*0004	'04 - '06	MK-HO01-T001	75	Mounting Kit top/tank
	CBR 125 R	JC 39	e13*0185	'07 - '08	MK-HO01-T001	75	Mounting Kit top/tank
Triumph (GB)	Daytona 675 i	D 67 LC	e11*0253	'06 - '12	MK-TR06-T002	75	Mounting Kit top/tank
	Daytona 675 i	D 67 LC	e11*0253	'06 - '12	MK-TR06-O002	75 reversed	Mounting Kit on original place
	Speed Triple 1050 i	515 NJ	e11*0439	'05 - '10	MK-TR10-B001	75 reversed	Mounting Kit under low. tripleclamp
	Street Triple 675 i	D 67 LD	e11*0611	'07 - '11	MK-TR06-T003	75	Mounting Kit top/tank

**Prüfbericht**  
**Nr.: GTÜ StVZO22-14003.02**  
**zur Beantragung eines Nachtrags zur ABE Nr. KBA 91325\*02**  
**nach § 22 StVZO Austausch-Lenkungsdämpfer für Krafträder**



Fahrzeugteilarart : Lenkungsdämpfer für Krafträder  
 Typ : DS  
 Antragsteller : Hyper Pro Sales B.V., NL-4251 LR Werkendam

**Anlage 1**

Fahrzeug Hersteller	Fahrzeug Handelsbezeichnung	TYP	EG-BE / ABE	Baujahr	Ausführung	Hub	Montage
	Street Triple R 675 i	D 67 LD	e11*0611	'07 - '12	MK-TR06-T003	75	Mounting Kit top/tank
	Street Triple R 675 i	D 67 LD 3	e11*0976	'09 - '10	MK-TR06-T003	75	Mounting Kit top/tank
	TT 600	806 AD	e11*00021	'00 - '03	MK-TR06-B001	75	Mounting Kit under low. tripleclamp
Voxan (F)	1000 V 2 Cafe Racer	V 2	e2*0016	'00 - '06	MK-VO10-S001	140	Mounting Kit right on frame
Yamaha (I)	NSR 1100 (BT 1100 Bulldog)	RP 05	e1*00116	'04 - '05	MK-YA11-S001	160	Mounting Kit left on frame
Yamaha (J)	FZ 1	RN 16	e13*0040	'05 ->	MK-YA10-T008	75	Mounting Kit top/tank
	FZ 1 ABS	RN 16	e13*0040	'06 ->	MK-YA10-T008	75	Mounting Kit top/tank
	FZ 1 Fazer	RN 16	e13*0040	'05 ->	MK-YA10-T008	75	Mounting Kit top/tank
	FZ 1 Fazer ABS	RN 16	e13*0040	'06 ->	MK-YA10-T008	75	Mounting Kit top/tank
	FZS 1000 Fazer	RN 06	e1*00103	'00 - '04	MK-YA10-T006	75	Mounting Kit top/tank
	FZS 1000 Fazer	RN 14	e13*0021	'04 - '05	MK-YA10-T006	75	Mounting Kit top/tank
	TRX 850	4 UN	H 283	'95 - '97	MK-YA08-S001	140	Mounting Kit right upp. frametube
	XJR 1200	4 PU	G 978	'95 - '99	MK-YA12-B002	75	Mounting Kit under low. tripleclamp
	XJR 1300	RP 02	K 266	'98 - '01	MK-YA13-B001	75	Mounting Kit under low. tripleclamp
	XJR 1300	RP 06	e1*00134	'02 - '03	MK-YA13-B002	75	Mounting Kit under low. tripleclamp
	XJR 1300	RP 10	e1*0204	'03 - '06	MK-YA13-B002	75	Mounting Kit under low. tripleclamp
	XJR 1300	RP 19	e13*0168	'06 ->	MK-YA13-B002	75	Mounting Kit under low. tripleclamp
	VMX 1200 Vmax	2 EN	-	'96 - '02	MK-YA12-T002	75	Mounting Kit top/tank
	VMX 1200 Vmax	3 UF	-	'96 - '99	MK-YA12-T002	75	Mounting Kit top/tank
	VMX 1200 Vmax	3 WF	-	'96 - '02	MK-YA12-T002	75	Mounting Kit top/tank
	YZF R 1	RN 01	H 917	'97 - '99	MK-YA10-T004	75	Mounting Kit top/tank
	YZF R 1	RN 04	e1*00063	'98 - '01	MK-YA10-T005	75	Mounting Kit top/tank
	YZF R 1	RN 09	e13*0054	'01 - '03	MK-YA10-T007	75	Mounting Kit top/tank
	YZF R 1	RN 12	e13*0084	'04 - '06	MK-YA10-O002	75	Mounting Kit on original place
	YZF R 1	RN 19	e13*0163	'07 - '08	MK-YA10-O002	75	Mounting Kit on original place

**Prüfbericht**  
**Nr.: GTÜ StVZO22-14003.02**  
**zur Beantragung eines Nachtrags zur ABE Nr. KBA 91325\*02**  
**nach § 22 StVZO Austausch-Lenkungsdämpfer für Krafträder**



Fahrzeugteilarart : Lenkungsdämpfer für Krafträder  
 Typ : DS  
 Antragsteller : Hyper Pro Sales B.V., NL-4251 LR Werkendam

**Anlage 1**

Fahrzeug Hersteller	Fahrzeug Handelsbezeichnung	TYP	EG-BE / ABE	Baujahr	Ausführung	Hub	Montage
	YZF R 1	RN 22	e13*0325	'09 - '11	MK-YA10-O003	75	Mounting Kit on original place
	YZF R 6	RJ 03	K 265	'98 - '00	MK-YA06-T002	75	Mounting Kit top/tank
	YZF R 6	RJ 03	K 265	'01 - '02	MK-YA06-T003	75	Mounting Kit top/tank
	YZF R 6	RJ 03	K 265	'98 - '02	MK-YA06-S001	160	Mounting Kit left on Deltaframe
	YZF R 6	RJ 05	e13*0060	'02 - '03	MK-YA06-T004	75	Mounting Kit top/tank
	YZF R 6	RJ 09	e13*0073	'03 - '05	MK-YA06-T004	75	Mounting Kit top/tank
	YZF R 6	RJ 11	e13*0038	'05 - '06	MK-YA06-T005	75	Mounting Kit top/tank
	YZF R 6	RJ 15	e13*0223	'06 ->	MK-YA06-T005	75	Mounting Kit top/tank
	YZF R 6 Race	RJ 15	e13*0223	'08 ->	MK-YA06-B002	75 reversed	Mounting Kit under low. tripleclamp

**Prüfbericht**  
**Nr.: GTÜ StVZO22-14003.01**  
**zur Beantragung eines Nachtrags zur ABE Nr. KBA 91325\*01**  
**nach § 22 StVZO Austausch-Lenkungsdämpfer für Krafträder**

Fahrzeugteilart : Lenkungsdämpfer für Krafträder  
 Typ : DS  
 Antragsteller : Hyper Pro Sales B.V., NL-4251 LR Werkendam

**Anlage 2**

Beschreibung der Bauteile

Stand: 21.04.2014

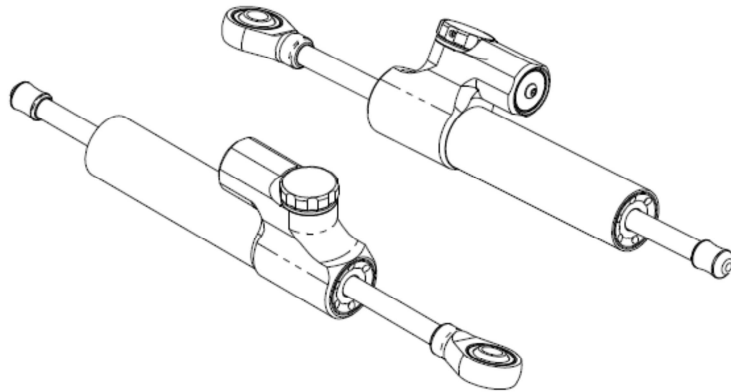

<b><i>DIMENSIONS in [mm]</i></b>					
	A	B	C	D	E
Stroke 68	227	121.5	53	109.5	24
Stroke 75	243	128.5	53	116.5	26
Stroke 120	333	173.5	53	151.5	26
Stroke 140	373	193.5	53	171.5	26
Stroke 160	413	213.5	53	191.5	26

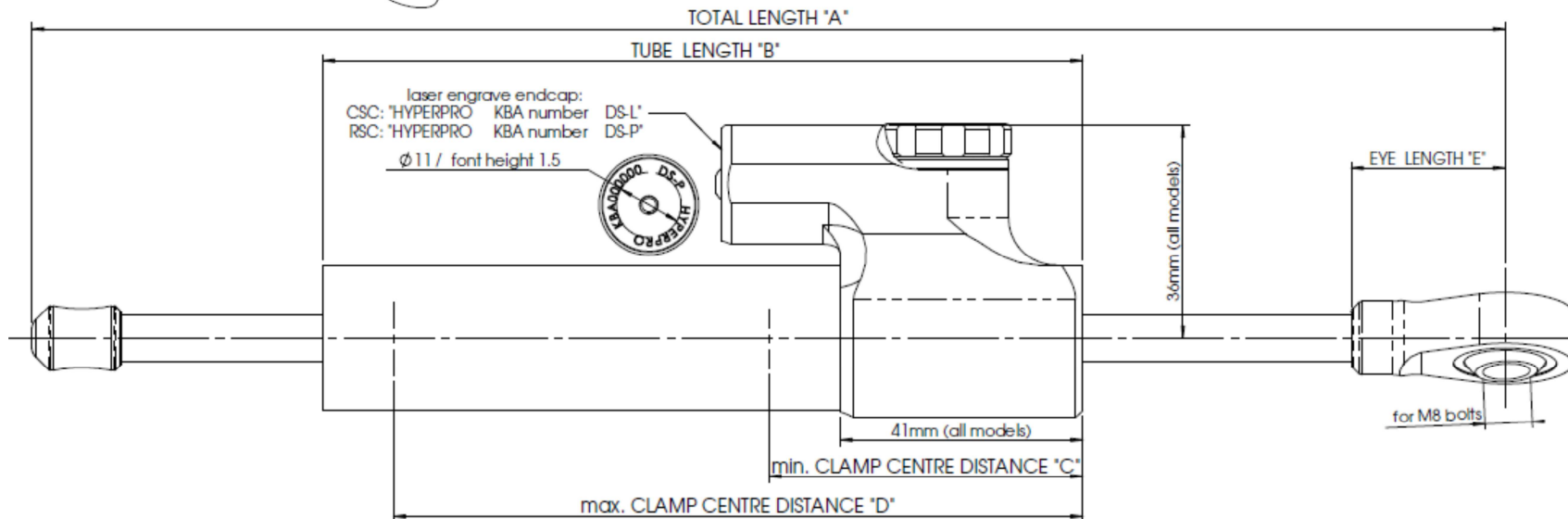

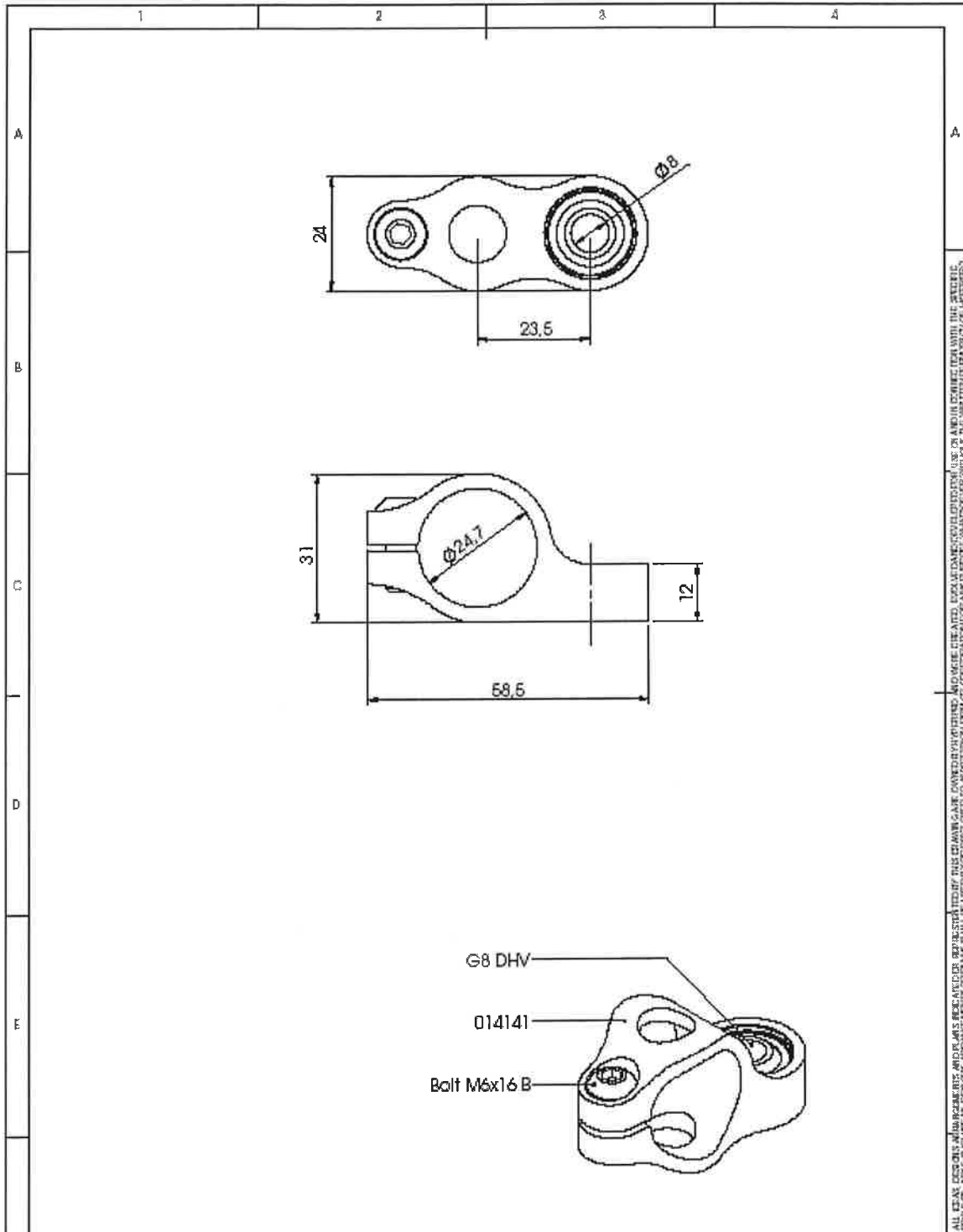

ALL CAD AND 3D MODELS ARE UNOFFICIAL. THEY ARE NOT TO BE USED FOR CONSTRUCTION OR REPRODUCTION. THE USER ASSUMES ALL LIABILITY FOR ANY DAMAGE OR LOSS OF DATA. THE USER ASSUMES ALL LIABILITY FOR ANY DAMAGE OR LOSS OF DATA. THE USER ASSUMES ALL LIABILITY FOR ANY DAMAGE OR LOSS OF DATA.

<p>                 ALL RIGHTS RESERVED. HYPERPRO                  HYPERPRO ENGINEERING                  KRAVCEVA VESTERAT 2, 4221 LE                  THE REPUBLIC OF CZECHIA                  TEL: +420 78 626 111, FAX: +420 78 626 112                  E-MAIL: hyperpro@hyperpro.cz, www.hyperpro.cz             </p>	DRAWN BY FORNY CREATED 9-11-2010 LAST SAVE 9-11-2010	F 00000000 E 00000000 D 00000000 C 00000000 B 00000000 A 00000000	PART NAME <b>Damper Clamp - Type 1</b> REFERENCE WEIGHT:
	UNLESS OTHERWISE SPECIFIED DIMENSIONS ARE IN MILLIMETERS	UNFINISHED DIMENSIONS ARE: 0 dec: 0.00 1 dec: 0.05 2 dec: 0.10 Angle: 20°	MP-DB018235 SHEET 1 OF 1
	SIZE A4, SCALE 1:1, DO NOT SCALE THIS DRAWING		





APR RSV1000 MILLE 98-00 AVAL 3300w - 7/12005

# HYPHERPRO

## STEERING DAMPER MOUNTING KIT

for  
**APRILIA RSV1000 MILLE**  
**Model 1998 - 2000<**

### MK-AP10-0001 PART LIST

SD stroke 75	1	-
Fork clamp $\phi$ 51	1	-
Spacer Type 1	1	-
Tube A adapter RSV	1	-
O-Ring	1	-
M8x35 Bulton head	1	-
Steering Lock Limiters	2	-
-	-	-

ALL DESIGNS, ARRANGEMENTS AND PLANS INDICATED OR REPRESENTED BY THE DRAWING ARE OWNED BY HYPERPRO. ANY REPRODUCTION, DISTRIBUTION, SALE, RENTAL, LEASE, OR USE OF THIS DRAWING OR ANY PART THEREOF FOR ANY PURPOSE WHATSOEVER WITHOUT THE WRITTEN PERMISSION OF HYPERPRO IS STRICTLY PROHIBITED.

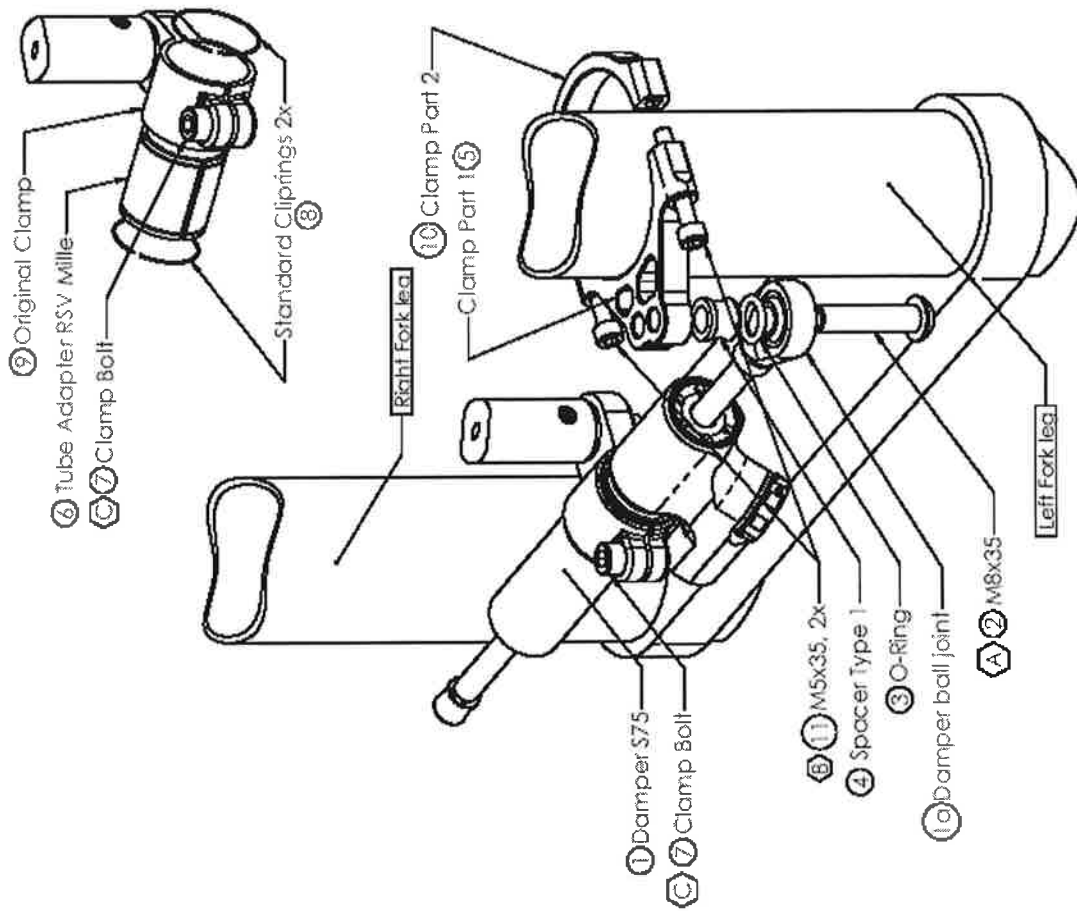
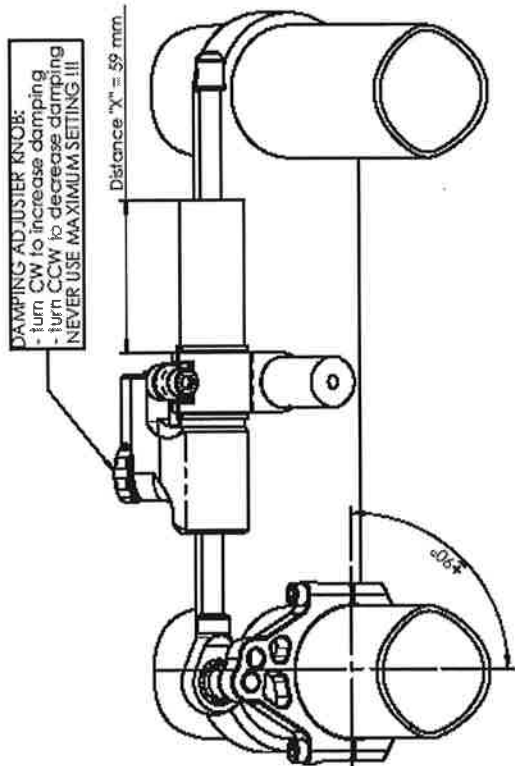

A 14.17Nm / 12.4-15.0Lbs.In / 10.3-12.5Lbs.Ft

B 8Nm / 7.0Lbs.In / 5.9Lbs.Ft

C 6Nm / 5.3Lbs.In / 4.4Lbs.Ft

See [WWW.HYPERPRO.COM](http://WWW.HYPERPRO.COM) for the latest pictures, modifications, specs. and e-drawings of this steering damper kit.

# HYPHERPRO

## STEERING DAMPER MOUNTING KIT

for

**APRILIA RSV1000 MILLE**

**Model 1998 - 2000<**

### MK-AP10-0001 INSTALLATION INSTRUCTIONS

#### In general:

HYPHERPRO can not be held responsible in any way for any form of physical, material, financial or other damage arising from use, assembly or overhaul of HYPHERPRO products. HYPHERPRO reserves the right to make changes without prior notice.

This product is ONLY TO BE INSTALLED BY A PROFESSIONAL MECHANIC.

This product is only to be used for the motorcycle brand, model and year stated specifically on top of the pages of this manual.

DO NOT attempt to install this product on motorcycles from any different brand, model and/or year than stated on the pages of this manual.

DO NOT use this kit for cars, boats, jet-skis, snowmobiles, ATVs, aircraft, hovercrafts or any other vehical and/or purpose.

HYPHERPRO steering dampers are FOR RACE USE ONLY, NOT FOR HIGHWAY USE!

#### Before installation:

- Please read the entire manual carefully before starting the installation!
- Check if you have all the tools required. Good tools are a must!
- Protect your bike at the most important places in and around the work area (e.g. tank, faying, frame, etc.), with a blanket, towel or similar.

#### During installation:

- Check all operations and parts carefully before, during and after performing each step.
- Clean all surfaces that are required for fitting parts together or for applying self adhesives or loctite, thoroughly with contactcleaner or another degreaser, unless otherwise stated.
- Be careful not to damage or scratch any part of your bike.
- ALWAYS work relaxed and concentrated! It is very easy to damage something or make a mistake.

#### After installation:

- Check and make sure that there is no contact between any part of the steering damper kit and any part of the motorcycle. The kit should not hit anything. Steering movement should not be limited by the steering damper. If the steering movement is limited, adjust the position of the tube in the clamp until steering movement is normal again. Do not forget to tighten the clamp bolt again!
- ALWAYS check the steering movement and feeling before each ride!
- FIRST RIDES: Start with the damper turned fully open (turn adjuster knob fully counter clockwise). Start adjusting in between rides with steps of MAX. 2 CLICKS (0.25 TURN) EACH TIME, until the damper is working satisfactory for your riding style.
- NEVER USE MAXIMUM SETTING, ALWAYS OPEN AT LEAST 2 CLICKS (0.25 TURN).

- WARNING ! DAMPER HAS AN ACTIVE / SPEEDSENSITIVE DAMPING SYSTEM;

- Steering with NORMAL MOVEMENT should be FREE !!

- Steering with FAST MOVEMENT should be CONTROLLED BY DAMPER !!

- HYPHERPRO uses a special seal to reduce friction. The seal uses an oil film to work properly.

It is normal that some oil can appear on the pistonrod.

- Damper works with oil. DAMPING CAN BE HARDER AT LOWER TEMPERATURES!

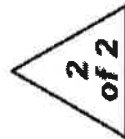

**See [WWW.HYPHERPRO.COM](http://WWW.HYPHERPRO.COM) for the latest pictures, modifications, specs. and e-drawings of this steering damper kit.**

## Montageanleitung Lenkungsdämpfer quer vor der Gabelbrücke

### Step 1: Remove original steering damper

### Step 2: Damper & clamp pre-assembly

Pre-assemble the clamps onto the damper using:

- Steering damper (1)
- Bolt M8x35 Button head (2)
- 1x O-Ring (3)
- Spacer Type 1 (4)
- Fork clamp Part 1 (5)

Disassemble the fork clamp. Fit clamp part 1 (5) to the balljoint of the steering damper (1a) using the M8x35 bolt (2), O-Ring (3) and spacer type 1 (4). Make sure it is assembled according to the pictures on page 1. Next tighten the bolt with a torque of approx. 14-17Nm/124-150Lbs.In/10.3-12.5Lbs.Ft.

### Step 3: Installing the steering lock limiters

Install the lock limiters using:

- Rubber 2mm steering lock limiters (self-adhesive)

Clean and degrease the left and right steering lock surfaces on the bottom of the steering head (see illustration). Stick the bumpers on the cleaned surfaces, so that the max steering angle will be limited by a few millimeters.

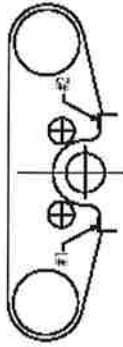

### Step 4: replacing the original damper

- Damper pre-assembly (from Step 2)
- Tube adapter for RSV Mille (6)

Remove the black plastic cover from the bottom of the lower triple tree, providing access to the bottom of the cockpit/frame. Loosen and remove the brake hose clamp from the front of the lower triple tree for better access.

Loosen clamp bolt (7), remove the standard clippings (8) (do not throw away!) and remove the M6 at the original damper ball joint. Mount tube adapter (6) in standard clamp (9) with opening in the same position and reposition the standard clippings (8). Do not tighten the clamp bolt (7) of the damper clamp (9) yet to install the damper to the front fairing subframe. Make sure it is assembled according to the pictures on page 1. Position the clamp at distance "X" (=59mm) and the damper body at the correct angle and tighten the clamp bolt with a torque of approximately 6Nm/53Lbs.In/4.4Lbs.Ft.

### Step 5: Installing the fork clamp

- Fork clamp Part 2 (10)
- 2x Bolt M5x35 (11)

Place the 2nd part of the fork clamp (10) on the fork leg, opposite to the 1st part (5). Fit the M5 bolts (11) and tighten them lightly and evenly. Check if the damper is level horizontally and tighten the bolts with a torque of approx. 8Nm/70Lbs.In/5.9Lbs.Ft.

Make sure that the damper has at least 2 mm clearance at full steering lock.

Check if the damper does not touch anything when steering from left to right. Check if the bike can make it's full steering angle from left to right, without being obstructed by the damper. If necessary re-position the clamp and re-tighten the bolts.

BAK-1207-3057-ACDhw - PN 2003

**Only fits when steering head  
is in original angle (24.5°)**

# HYPERRPRO

## STEERING DAMPER MOUNTING KIT

for  
**DUCATI 748 / 916 / 996 / 998**  
**Model 1994 ->**

### MK-DU07-T001 PART LIST

SD stroke 75	1	-
Tube Clamp TYPE 3	1	-
O-Ring	2	-
Spacer M6 to M8	1	-
M6x25 Button head	1	-
M6x20 Low head	1	-
Washer M6φ12	1	-
-	-	-

ALL RIGHTS RESERVED. REPLICATING OR DISTRIBUTING THIS DOCUMENT IS PROHIBITED. THE INFORMATION CONTAINED HEREIN IS THE PROPERTY OF HYPERPRO AND IS TO BE USED ONLY FOR THE PURPOSES INDICATED. ANY OTHER USE IS STRICTLY PROHIBITED. THE INFORMATION CONTAINED HEREIN IS THE PROPERTY OF HYPERPRO AND IS TO BE USED ONLY FOR THE PURPOSES INDICATED. ANY OTHER USE IS STRICTLY PROHIBITED.

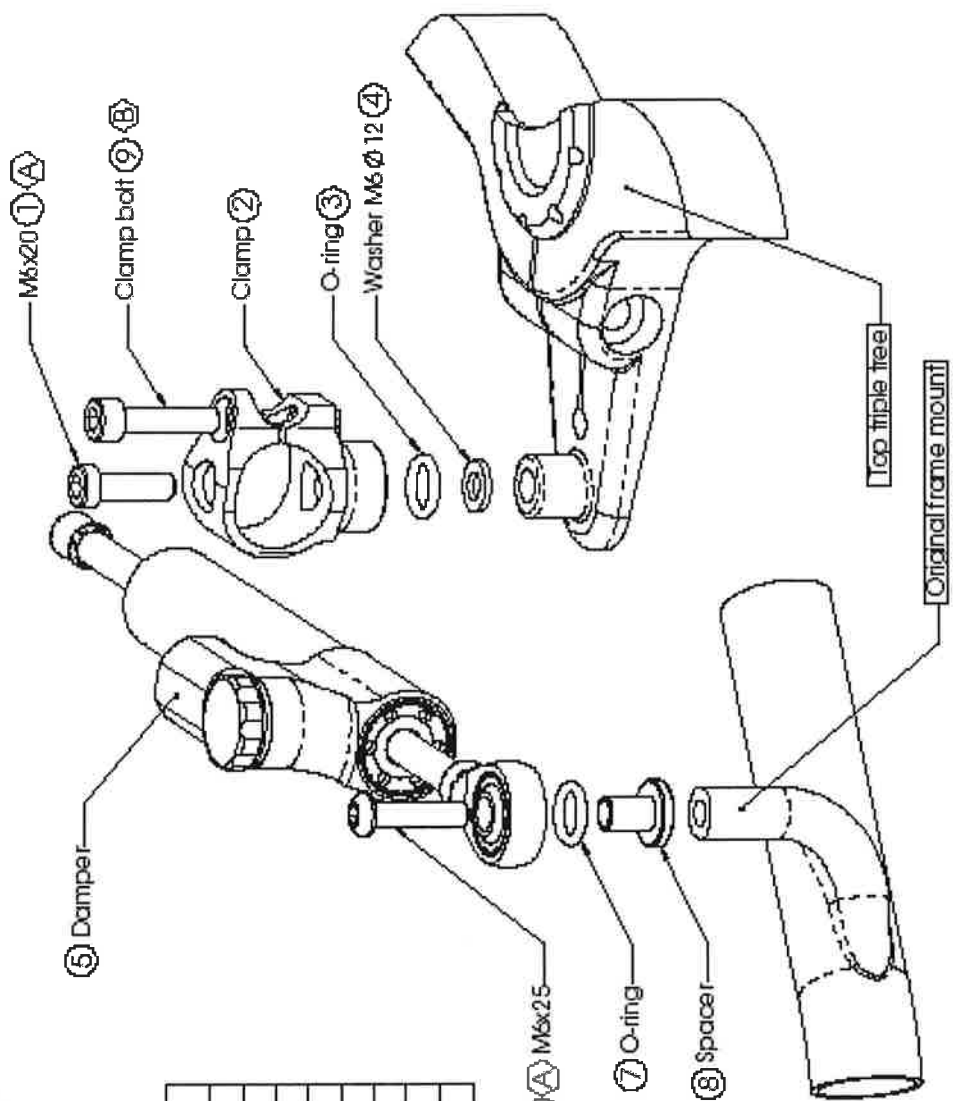

- Ⓐ 5.9Nm / 44.30lbs.in / 4.0-6.4lbs.ft
- Ⓑ 6Nm / 5.3lbs.in / 4.4lbs.ft

1  
of 2

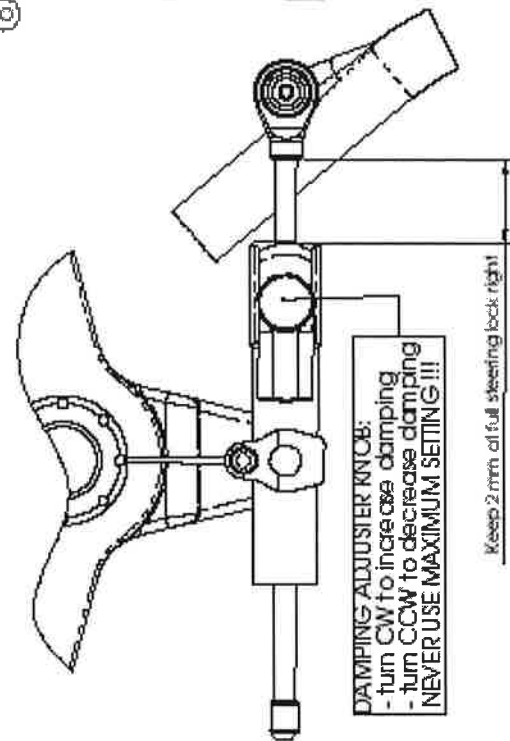

**DAMPING ADJUSTER KNOB:**  
 - turn CW to increase damping  
 - turn CCW to decrease damping  
**NEVER USE MAXIMUM SETTING!!!**

Keep 2mm of full steering lock right

See [WWW.HYPERRPRO.COM](http://WWW.HYPERRPRO.COM) for the latest pictures, modifications, specs. and e-drawings of this steering damper kit.

# HYPERRPRO

## STEERING DAMPER MOUNTING KIT

for

**DUCATI 748 / 916 / 996 / 998**  
**Model 1994 ->**

### MK-DU07-T001 INSTALLATION INSTRUCTIONS

#### In general:

HYPERRPRO can not be held responsible in any way for any form of physical, material, financial or other damage arising from use, assembly or overhaul of HYPERRPRO products. HYPERRPRO reserves the right to make changes without prior notice.

This product is ONLY TO BE INSTALLED BY A PROFESSIONAL MECHANIC. This product is only to be used for the motorcycle brand, model and year stated specifically on top of the pages of this manual. DO NOT attempt to install this product on motorcycles from any different brand, model and/or year than stated on the pages of this manual. DO NOT use this kit for cars, boats, jetskis, snowmobiles, ATVs, aircraft, hovercrafts or any other vehicles and/or purpose. HYPERRPRO steering dampers are FOR RACE USE ONLY, NOT FOR HIGHWAY USE!

#### Before installation:

- Please read the entire manual carefully before starting the installation!
- Check if you have all the tools required. Good tools are a must!
- Protect your bike at the most important places it and around the work area (e.g. tank, faining, frame, etc.) with a blanket, towel or similar.

#### During installation:

- Check all operations and parts carefully before, during and after performing each step.
- Clean all surfaces that are required for fitting parts together or for applying seal adhesives or lockite, thoroughly with contact cleaner or another degreaser, unless otherwise stated.
- Be careful not to damage or scratch any part of your bike.
- ALWAYS work relaxed and concentrated! It is very easy to damage something or make a mistake.

#### After installation:

- Check and make sure that there is no contact between any part of the steering damper kit and any part of the motorcycle. The kit should not hit anything. Steering movement should not be limited by the steering damper. If the steering movement is limited, adjust the position of the tube in the clamp until steering movement is normal again. Do not forget to tighten the clamp bolt again!
- ALWAYS check the steering movement and feeling before each ride!
- FIRST RIDES: Start with the damper turned fully open (full adjuster knob fully counter clockwise). Start adjusting in between rides with steps of MAX. 2 CLICKS (0.25 TURN) EACH TIME, until the damper is working satisfactory for your riding style.
- NEVER USE MAXIMUM SETTING, ALWAYS OPEN AT LEAST 2 CLICKS (0.25 TURN).
- WARNING! DAMPER HAS AN ACTIVE / SPEED SENSITIVE DAMPING SYSTEM
- Steering with NORMAL MOVEMENT should be FREE !!
- Steering with FAST MOVEMENT should be CONTROLLED BY DAMPER !!
- HYPERRPRO uses a special seal to reduce friction. The seal uses an oil film to work properly. It is normal that some oil can appear on the piston rod.
- Damper works with oil: DAMPING CAN BE HARDER AT LOWER TEMPERATURES!

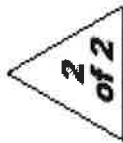

### Step 1: REMOVE THE ORIGINAL STEERING-DAMPER

### Step 2: Installing the tube clamp

- Bolt M6x20 low head (1)
- Tube Clamp Type 3 (2)
- O-Ring (3)
- Washer M6ø12 (4)

Put the assembly together as shown on page 1. Take the tube damp (2), use the bolt (1), O-ring (3), and the washers (4) to fit to the M6 hole in the top triple tree. Tighten the bolt with a torque of approx. 5-9 Nm/44-80 lbs. In/4.0-6.4 lbs. Ft.

### Step 3: installing the steering damper

- Steering damper (5)
- Bolt M6x25 buttonhead (6)
- O-ring (7)
- Spacer M6 to M8 (8)

Shove the damper (10), with the end knob-side first, through the clamp until the ball joint can be fitted to the frame mount. As shown on page 1: O-ring (7), spacer (8) and M6 bolt (6) to fix the ball joint to the frame and tighten with a torque of approx. 5-9 Nm/44-80 lbs. In/4.0-6.4 lbs. Ft. Position the damper tube so the bike can make its full steering angle without being obstructed by the steering damper, make sure that the damper has at least 2 mm clearance at full steering lock. Tighten the M6 clamp bolt (9) with a torque of approx. 6 Nm/53 lbs. In/4.4 lbs. Ft.

Check if the damper is level horizontally and aligned to the bike. Check if the damper does not touch anything (e.g. tank) when steering from left to right. Check if the bike can make its full steering angle from left to right and adjust if necessary.

See [WWW.HYPERRPRO.COM](http://WWW.HYPERRPRO.COM) for the latest pictures, modifications, specs. and drawings of this steering damper kit.